



Maintenance and Service Guide

HP Pavilion dv8000 Notebook PC

Document Part Number: 403248-001

November 2005

This guide is a troubleshooting reference used for maintaining and servicing the computer. It provides comprehensive information on identifying computer features, components, and spare parts; troubleshooting computer problems; and performing computer disassembly procedures.

© Copyright 2005 Hewlett-Packard Development Company, L.P.

Microsoft and Windows are U.S. registered trademarks of Microsoft Corporation. AMD, Turion, and combinations thereof, are trademarks of Advanced Micro Devices, Inc. Bluetooth is a trademark owned by its proprietor and used by Hewlett-Packard Company under license. SD Logo is a trademark of its proprietor.

The information contained herein is subject to change without notice. The only warranties for HP products and services are set forth in the express warranty statements accompanying such products and services. Nothing herein should be construed as constituting an additional warranty. HP shall not be liable for technical or editorial errors or omissions contained herein.

Maintenance and Service Guide
HP Pavilion dv8000 Notebook PC
First Edition November 2005
Document Part Number: 403248-001

Contents

1 Product Description

1.1 Features	1-2
1.2 Resetting the Computer.	1-4
1.3 Power Management.	1-5
1.4 External Components	1-6
1.5 Design Overview.	1-24

2 Troubleshooting

2.1 Computer Setup.	2-1
Accessing Computer Setup.	2-2
Computer Setup Defaults	2-2
Selecting from the File Menu	2-3
Selecting from the Security Menu	2-4
Selecting from the Tools Menu.	2-5
Selecting from the Advanced Menu	2-6
2.2 Troubleshooting Flowcharts	2-7

3 Illustrated Parts Catalog

3.1 Serial Number Location	3-1
3.2 Computer Major Components	3-2
3.3 Display Assembly Subcomponents	3-10
3.4 Plastics Kit	3-12
3.5 Cable Kit	3-13
3.6 Mass Storage Devices	3-14
3.7 Miscellaneous (Not Illustrated)	3-16
3.8 Sequential Part Number Listing	3-17

4 Removal and Replacement Preliminaries

4.1 Tools Required	4-1
4.2 Service Considerations	4-2
Plastic Parts	4-2
Cables and Connectors	4-2
4.3 Preventing Damage to Removable Drives	4-3
4.4 Preventing Electrostatic Damage	4-4
4.5 Packaging and Transporting Precautions	4-5
4.6 Workstation Precautions	4-6
4.7 Grounding Equipment and Methods	4-6

5 Removal and Replacement Procedures

5.1	Serial Number	5-2
5.2	Disassembly Sequence Chart	5-3
5.3	Preparing the Computer for Disassembly	5-5
5.4	Hard Drive	5-7
5.5	Computer Feet	5-11
5.6	Memory Module	5-12
5.7	Mini PCI Communications Module	5-16
5.8	RTC Battery	5-18
5.9	Optical Drive	5-20
5.10	Switch Cover	5-22
5.11	Keyboard Assembly Frame	5-24
5.12	LED Board	5-28
5.13	Keyboard	5-30
5.14	Display Assembly	5-32
5.15	Top Cover	5-43
5.16	System Board	5-50
5.17	Bluetooth Module	5-57
5.18	Modem Connector Cable	5-60
5.19	USB Board	5-62
5.20	Speakers	5-64
5.21	Heat Sink	5-67
5.22	Processor	5-70
5.23	Fan Assembly	5-72
5.24	PC Card Assembly	5-76

6 Specifications

A Connector Pin Assignments

B Power Cord Set Requirements

C Screw Listing

D Display Component Recycling

1

Product Description

The HP Pavilion dv8000 Notebook PC offers advanced modularity, AMD Turion™ 64 Mobile Technology processors, and extensive multimedia support.



HP Pavilion dv8000 Notebook PC

1.1 Features

- AMD Turion 64 ML-40 (2.2-GHz), ML-37 (2.0-GHz), or ML-30 (1.6-GHz) processors, all with 1-MB L2 cache, or ML-32 (1.8-GHz) processor with 512-MB L2 cache, varying by computer model
- 17.0-inch, WSXGA+, TFT (1680 × 1050) with BrightView or 17.0-inch, WXGA+, TFT (1440 × 900) with BrightView display, varying by computer model
- 120-, 100-, or 80-GB high-capacity hard drive, varying by computer model
- 256-MB DDR1 synchronous DRAM (SDRAM) at 333 MHz, expandable to 2.0 GB
- Microsoft® Windows® XP Home Edition or Windows XP Professional, varying by computer model
- Full-size Windows keyboard with full-size numeric keypad
- TouchPad pointing device, including dedicated vertical scroll region
- Integrated 10Base-T/100Base-TX Ethernet local area network (LAN) network interface card (NIC) with RJ-45 jack
- Integrated high-speed 56K modem with RJ-11 jack
- Integrated wireless support for Mini PCI IEEE 802.11a/b/g WLAN device
- Support for one Type I or Type II PC Card slot, with support for both 32-bit (CardBus) and 16-bit PC Cards
- Support for ExpressCard slot

- External 65-watt AC adapter with 3-wire power cord
- 8-cell Li-Ion battery pack
- Stereo speakers
- Volume up, volume mute, and volume down buttons
- QuickPlay buttons
- Support for the following optical drives:
 - ❑ DVD±RW and CD-RW Double Layer Combo Drive with LightScribe
 - ❑ DVD±RW and CD-RW Double Layer Combo Drive
 - ❑ DVD/CD-RW Combo Drive
- Connectors:
 - ❑ Audio-in (microphone)
 - ❑ Audio-out (headphone)
 - ❑ Digital Media Slot
 - ❑ Expansion port 2
 - ❑ ExpressCard slot
 - ❑ External monitor
 - ❑ IEEE 1394
 - ❑ PC Card
 - ❑ Power
 - ❑ RJ-11 (modem)
 - ❑ RJ-45 (network)
 - ❑ S-Video-out
 - ❑ Universal Serial Bus (USB) v. 2.0 (4 ports)

1.2 Resetting the Computer

If the computer you are servicing has an unknown password, follow these steps to clear the password. These steps also clear CMOS:

1. Enter an incorrect password and press **enter**.
2. Repeat Step 1 two times.

After the third entry of the incorrect password, the computer responds with a “System Disabled” message and provides an override password.

3. Access MS/DOS by clicking **Start > All Programs > Accessories > Command Prompt**.
4. Enter “unlock6 xxxxx 0,” where “xxxxx” is the password generated by the computer in Step 2.

The computer responds with another system-generated password. This password can be used to reset the computer and clear all CMOS settings.

1.3 Power Management

The computer comes with power management features that extend battery operating time and conserve power. The computer supports the following power management features:

- Standby
- Hibernation
- Setting customization by the user
- Hotkeys for setting the level of performance
- Battery calibration
- Lid switch standby/resume
- Power button
- Advanced Configuration and Power Management (ACPM) compliance

1.4 External Components

The external components on the front of the computer are shown below and described in Table 1-1.

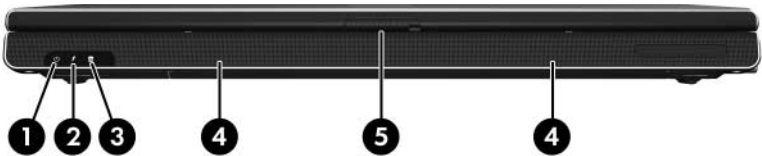

Front Components

Table 1-1
Front Components

Item	Component	Function
1	Power light	<ul style="list-style-type: none"> ■ On: Computer is turned on. ■ Off: Computer is off or in hibernation. ■ Blinking: Computer is in standby.
2	Battery light	<ul style="list-style-type: none"> ■ On: A battery pack is charging or is close to full charge capacity. ■ Off: If the computer is plugged into an external power source, the light is turned off when all batteries in the computer are fully charged. If the computer is not plugged into an external power source, the light stays off until the battery reaches a low-battery condition. ■ Blinking: A battery pack that is the only available power source has reached a low-battery condition. When the battery reaches a critical low-battery condition, the battery light begins blinking quickly.
3	Integrated Drive Electronics (IDE) drive light	On or blinking: The internal hard drive or an optical drive is being accessed.
4	Speakers	Produce stereo sound.
5	Display release latch	Opens the computer.

The external components on the right side of the computer are shown below and described in Table 1-2.

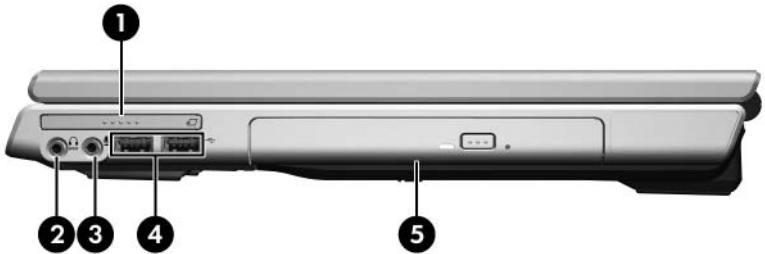

Right-Side Components

Table 1-2
Right-Side Components

Item	Component	Function
1	ExpressCard slot	Supports an optional ExpressCard.
2	Audio-out (headphone) jack	Connects an optional headphone or powered stereo speakers. Also connects the audio function of an audio/video device, such as a television or VCR.
3	Audio-in (microphone) jack	Connects an optional stereo microphone.
4	USB ports (2)	Connect optional USB devices.
5	Optical drive	Supports an optical disc, such as a CD or DVD.

The external components on the left side of the computer are shown below and described in Table 1-3.

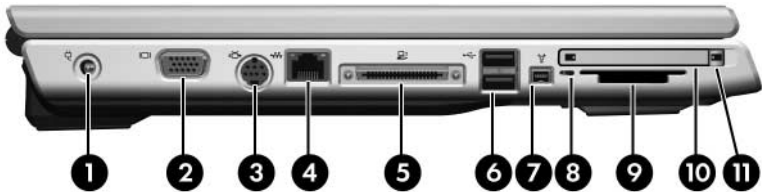

Left-Side Components

Table 1-3

Left-Side Components

Item	Component	Function
1	Power connector	Connects the AC adapter cable.
2	Monitor port	Connects an optional VGA monitor or projector.
3	S-Video-out jack	Connects the video function of an optional S-Video device, such as a television, VCR, or video capture card.
4	RJ-45 (network) jack	Connects a network cable (not included).

Table 1-3
Left-Side Components (*Continued*)

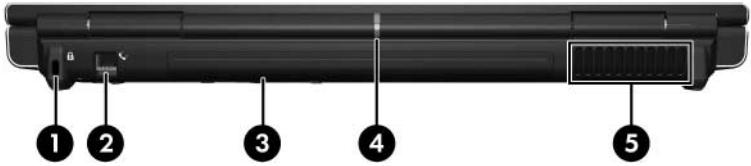

Item	Component	Function
5	Expansion port 2	Connects the computer to an optional docking device.  The computer has only one expansion port. The term <i>expansion port 2</i> describes the type of expansion port.
6	USB ports (2)	Connect optional USB devices.
7	1394 port (4-pin)	Connects an optional 1394a device such as a scanner, a digital camera, or a digital camcorder.
8	Digital Media Slot light	On: An optional digital card is being accessed.
9	Digital Media Slot	Supports the following optional digital cards: SD (Secure Digital) Memory Card, SD I/O Card, Memory Stick, Memory Stick Pro, MultiMediaCard, xD-Picture Card, and SmartMedia.
10	PC Card slot	Supports an optional Type I or Type II 32-bit (CardBus) or 16-bit PC Card.
11	PC Card eject button	Ejects PC Cards from the PC Card slot.

The external components on the rear panel of the computer are shown below and described in Table 1-4.



Rear Panel Components

Table 1-4
Rear Panel Components

Item	Component	Function
1	Security cable slot	<p>Attaches an optional security cable to the computer.</p> <p> The purpose of security solutions is to act as a deterrent. These solutions do not prevent the product from being mishandled or stolen.</p>
2	RJ-11 (modem) jack	Connects a modem cable (not included).
3	Battery bay	Holds a battery pack.
4	Wireless light	<p>On: One or more internal wireless devices have been turned on.</p> <p> To establish a wireless connection, a wireless network must already be set up.</p>
5	Vent	<p>Provides airflow to cool internal components.</p> <p> To prevent overheating, do not obstruct vents. Do not allow a hard surface, such as a printer, or a soft surface, such as pillows or thick rugs or clothing, to block airflow.</p>

The standard keyboard components of the computer are shown below and described in Table 1-5.

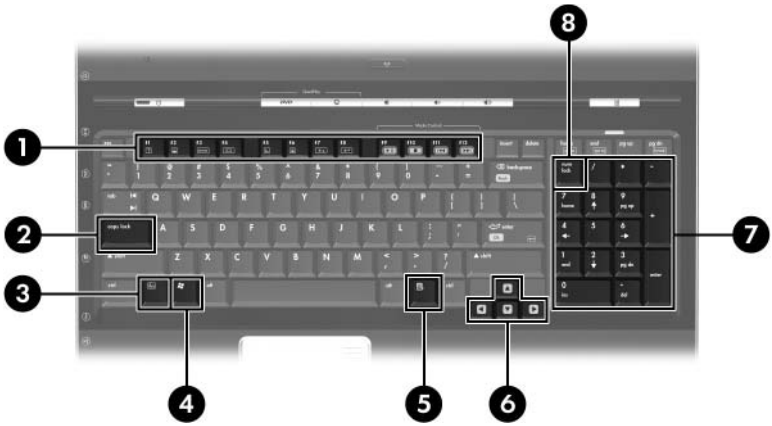

Standard Keyboard Components

Table 1-5
Standard Keyboard Components

Item	Component	Function
1	f1 to f12 keys (12)	Perform system and application tasks. When combined with fn , function keys perform additional tasks as hotkeys.
2	caps lock key	Enables caps lock and turns on the caps lock light.
3	fn key	Combines with other keys to perform system tasks as hotkeys. For example, pressing fn+f7 decreases screen brightness.
4	Windows logo key	Displays the Microsoft Windows Start menu.
5	Windows applications key	Displays a shortcut menu for items beneath the pointer.
6	Arrow keys	Move the cursor around the screen.
7	Numeric keypad keys (16)	Can be used like the keys on an external numeric keypad.
8	num lock key	Enables numeric lock, turns on the embedded numeric keypad, and turns on the num lock light.

The computer top components are shown below and described in Table 1-6.

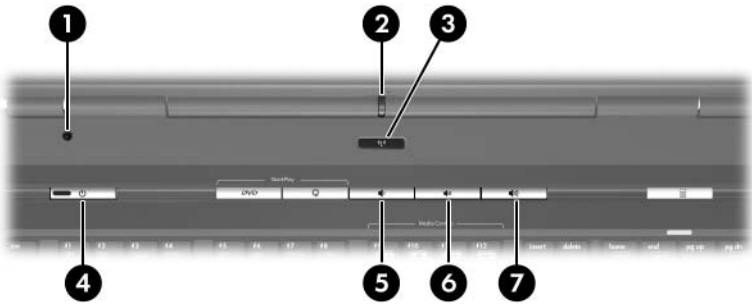

Top Components

Table 1-6
Top Components



Item	Component	Function
1	Display switch	Initiates standby if the display is closed when the computer is on.
2	Wireless light	On: One or more internal wireless devices have been turned on.  To establish a wireless connection, a wireless network must already be set up.

Table 1-6
Top Components (*Continued*)

Item	Component	Function
3	Wireless button	<p>Turns the wireless functionality on or off, but does not create a wireless connection.</p> <p> To establish a wireless connection, a wireless network must already be set up.</p>
4	Power light Power button	<p>■ On: The computer is on. ■ Blinking: The computer is in standby. ■ Off: The computer is off or in hibernation.</p> <p>When the computer is</p> <p>■ Off, press to turn on the computer. ■ On, press to enter hibernation. ■ In standby, briefly press to exit standby. ■ In hibernation, briefly press to exit hibernation.</p> <p>If the computer has stopped responding and Microsoft® Windows® shutdown procedures cannot be used, press and hold the power button for at least 5 seconds to turn off the computer.</p>
5	Volume down button	Decreases system volume.
6	Volume mute button	Mutes or restores volume.
7	Volume up button	Increases system volume.

The Quick Play and Quick Launch buttons are shown below and described in Table 1-7.

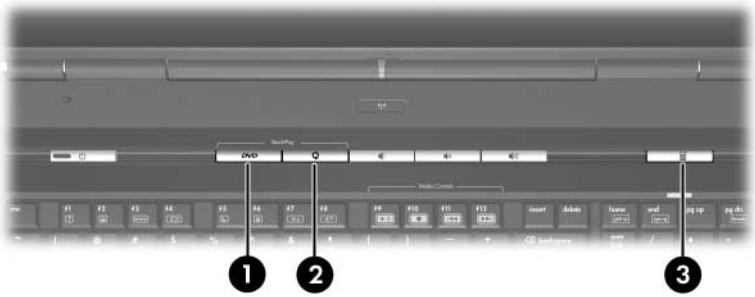

Top Components

Table 1-7

QuickPlay and Quick Launch Button Components

Item	Component	Function
1	DVD button	<p>Default button functions without QuickPlay software:</p> <p>When the computer is</p> <ul style="list-style-type: none"> ■ On: Opens the default DVD application to start a DVD in the optical drive. ■ Off: No function. ■ In standby: Resumes from standby into Windows. ■ In hibernation: Restores from hibernation into Windows. <p>Button functions with QuickPlay software:</p> <p>When the computer is</p> <ul style="list-style-type: none"> ■ On: Opens the default DVD application to start a DVD in the optical drive. ■ Off: Opens QuickPlay to start a DVD in the optical drive. ■ In standby: Resumes from standby into Windows. ■ In hibernation: Restores from hibernation into Windows.

Table 1-7

QuickPlay and Quick Launch Button Components (*Continued*)

Item	Component	Function
2	Media Button	<p>Default button functions without QuickPlay software:</p> <p>When the computer is</p> <ul style="list-style-type: none"> ■ On: Opens the music application or the Media menu, allowing you to select a multimedia application. ■ Off: No function. ■ In standby: Resumes from standby into Windows. ■ In hibernation: Restores from hibernation into Windows. <p>Button functions with QuickPlay software:</p> <p>When the computer is</p> <ul style="list-style-type: none"> ■ On: Opens the music application or the Media menu, allowing you to select a multimedia application. ■ Off: Opens the music application or the Media menu, allowing you to select a multimedia application. ■ In standby: Resumes from standby into Windows. ■ In hibernation: Restores from hibernation into Windows.
3	Quick Launch calculator button	<p>Opens the Microsoft Windows calculator. This button can also be reassigned to an Internet or network destination or to any software application or data file.</p> <p> When you press the Quick Launch calculator button, num lock is enabled.</p>

The computer TouchPad components are shown below and described in Table 1-8.

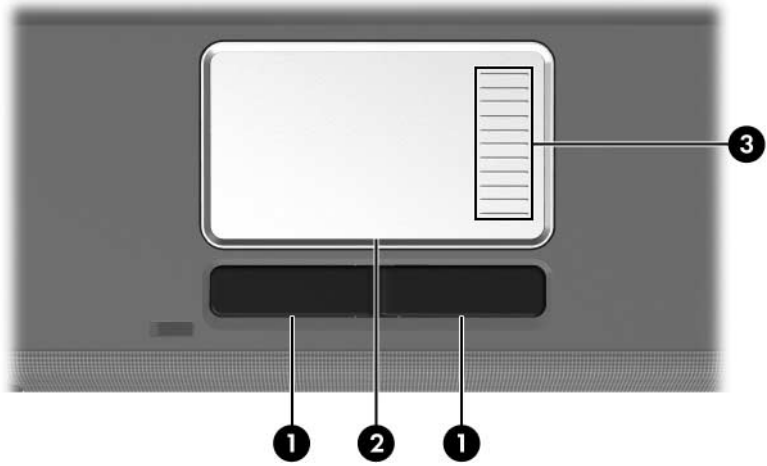

TouchPad Components

Table 1-8

TouchPad Components

Item	Component	Function
1	Left and right TouchPad buttons	Function like the left and right buttons on an external mouse.
2	TouchPad	Moves the pointer and selects or activates items on the screen. Can be set to perform other mouse functions, such as scrolling, selecting, and double-clicking.
3	TouchPad vertical scroll zone	Scrolls up or down.

The external components on the bottom of the computer are shown below and described in Table 1-9.

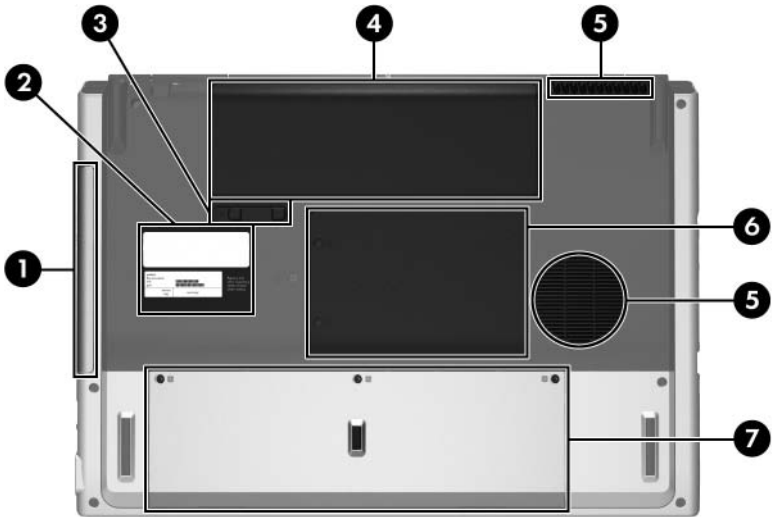



Bottom Components

Table 1-9
Bottom Components

Item	Component	Function
1	Optical drive	Supports an optical disc, such as a CD or DVD.
2	Labels area	Contains the serial number and other information labels.
3	Battery pack release latch	Releases a battery pack from the battery bay.
4	Battery bay	Holds a battery pack.

Table 1-9
Bottom Components (*Continued*)

Item	Component	Function
5	Vents (2)	<p>Provide airflow to cool internal components.</p> <p> To prevent overheating, do not obstruct vents. Do not allow a hard surface, such as a printer, or a soft surface, such as pillows or thick rugs or clothing, to block airflow.</p>
6	Memory/Mini PCI module compartment cover	<ul style="list-style-type: none"> <li data-bbox="525 613 948 748">■ Contains 2 memory module slots that support replaceable memory modules. The number of preinstalled memory modules varies by computer model. <li data-bbox="525 760 889 813">■ Holds an optional wireless LAN device (select models only). <p> To prevent an unresponsive system and the display of a warning message, install only a Mini PCI device authorized for use in your computer by the governmental agency that regulates wireless devices in your country. If you install an unauthorized device and then receive a warning message, remove the device to restore computer functionality. Then contact Customer Care.</p>
7	Hard drive bay	Holds the internal hard drive.

1.5 Design Overview

This section presents a design overview of key parts and features of the computer. Refer to [Chapter 3, “Illustrated Parts Catalog,”](#) to identify replacement parts, and [Chapter 5, “Removal and Replacement Procedures,”](#) for disassembly steps.

The system board provides the following device connections:

- AMD Turion 64 processors
- Audio
- Digital media card
- Display
- ExpressCard
- Hard drive
- Keyboard
- Memory module
- Mini PCI communications devices
- PC Card
- TouchPad



CAUTION: To properly ventilate the computer, allow at least a 7.6-cm (3-inch) clearance on the left and right sides of the computer.

The computer uses an electric fan for ventilation. The fan is controlled by a temperature sensor and is designed to be turned on automatically when high temperature conditions exist. These conditions are affected by high external temperatures, system power consumption, power management/battery conservation configurations, battery fast charging, and software applications. Exhaust air is displaced through the ventilation grill located on the left side of the computer.

Troubleshooting



WARNING: Only authorized technicians trained by HP should repair this equipment. All troubleshooting and repair procedures are detailed to allow only subassembly-/module-level repair. Because of the complexity of the individual boards and subassemblies, do not attempt to make repairs at the component level or modifications to any printed wiring board. Improper repairs can create a safety hazard. Any indication of component replacement or printed wiring board modification may void any warranty or exchange allowances.

2.1 Computer Setup

Computer Setup is a preinstalled, ROM-based utility that can be used even when the operating system is not working or will not load. If the operating system is working, the computer restarts the operating system after you exit Computer Setup.



Pointing devices are not supported in Computer Setup; you must use the keyboard to navigate and make selections.

The menu tables later in this chapter provide an overview of Computer Setup options.

Accessing Computer Setup

The information and settings in Computer Setup are accessed from the File, Security, Tools, and Advanced menus.

1. Open Computer Setup by turning on or restarting the computer. Press **f10** while the F10 = Based Setup message is displayed in the lower-left corner of the screen.
 - To change the language, press **f2**.
 - To view navigation information, press **f1**.
 - To return to the Computer Setup menu, press **esc**.
2. Select the **File, Security, Tools, or Advanced** menu.
3. To exit Computer Setup, choose one of the following:
 - To exit without saving any changes, use the arrow keys to select **File > Ignore changes and exit**, and then follow the instructions on the screen.
 - To exit and save all the settings you have entered, use the arrow keys to select **File > Save changes and exit**, and then follow the instructions on the screen.

Your preferences are set when you exit Computer Setup and go into effect when the computer restarts.

Computer Setup Defaults

To return all settings in Computer Setup to the values that were set at the factory:

1. Open Computer Setup by turning on or restarting the computer. Press **f10** while the F10 = Based Setup message is displayed in the lower-left corner of the screen.
 - To change the language, press **f2**.
 - To view navigation information, press **f1**.
2. Use the arrow keys to select **File > Restore defaults**.
3. Select the **Restore Defaults** check box.

4. To confirm the restoration, press **f10**.
5. Select **File > Save changes and exit**, and then follow the instructions on the screen.

When the computer restarts, the factory settings are restored, and any identification information you have entered is saved.



Selecting from the File Menu

Table 2-1
File Menu

Select	To Do This
System Information	<ul style="list-style-type: none"> ■ View identification information about the computer and any battery packs in the system. ■ View specification information about the processor, memory and cache size, video revision, keyboard controller version, and system ROM.
Save to floppy	Save system configuration settings to a diskette.
Restore to floppy	Restore system configuration settings from a diskette.
Restore defaults	Replace configuration settings in Computer Setup with factory default settings. (Identification information is retained.)
Ignore changes and exit	Cancel changes entered during the current session. Then exit and restart the computer.
Save changes and exit	Save changes entered during the current session. Then exit and restart the computer. The changes you save are to into effect when the computer restarts.

Selecting from the Security Menu

Table 2-2
Security Menu

Select	To Do This
Administrator password	Enter, change, or delete an HP Administrator password.
Power-on password	Enter, change, or delete a power-on password.
Password options	<ul style="list-style-type: none"> ■ Enable/Disable stringent security. ■ Enable/Disable required password on restart.
DriveLock passwords	<p>Enable/disable DriveLock; change a DriveLock user or master password.</p> <p> DriveLock Settings are accessible only when you enter Computer Setup by turning on (not restarting) the computer.</p>
Smart Card Security	<p>Enable/disable power-on support for smart cards.</p> <p> This feature is supported by select smart card readers only.</p>
Embedded Security	<ul style="list-style-type: none"> ■ Enable/Disable the embedded security chip. ■ Restore embedded security chip to factory settings. ■ Enable/Disable power-on authentication support. ■ Enable/Disable automatic DriveLock. ■ Reset power-on authentication credential <p> Embedded Security settings are accessible only if the computer is equipped with an embedded security chip.</p>
Device security	<p>Enable/Disable devices in the system.</p> <p>Enable NIC for inclusion in MultiBoot.</p>
System IDs	Enter user-defined identification values.

Selecting from the Tools Menu

Table 2-3
Tools Menu

Select	To Do This
HDD Self Test options	Run a quick or comprehensive self-test on any hard drive in the system.
Battery Information	View information about any battery packs in the computer.
Memory Check	<ul style="list-style-type: none"> ■ Run a self-test on memory modules in the computer. ■ View information about memory modules installed in the computer.

Selecting from the Advanced Menu

Table 2-4
Advanced Menu

Select	To Do This
Language (or press f2)	Change the Computer Setup language.
Boot options	<ul style="list-style-type: none"> ■ Enable/Disable MultiBoot, which sets a startup sequence that can include most bootable devices and media in the system. ■ Set the boot order.
Device options	<ul style="list-style-type: none"> ■ Swap the functions of the fn key and left ctrl key. ■ Enable/Disable multiple pointing devices at startup. (To set the computer to support only a single, usually nonstandard, pointing device at startup, select Disable.) ■ Enable/Disable USB legacy support for a USB keyboard, mouse, and hub. When USB legacy support is enabled <ul style="list-style-type: none"> <input type="checkbox"/> A USB keyboard, mouse, and hub work even when a Windows operating system is not loaded. <input type="checkbox"/> The computer starts from a bootable hard drive, diskette drive diskette, or CD, CD-RW, or DVD inserted into a drive connected by a USB connector to the computer or to an optional docking device. ■ Select a parallel port mode: EPP (Enhanced Parallel Port), standard, bidirectional, or ECP (Enhanced Capabilities Port). ■ Enable/Disable all settings in the SpeedStep window. (When Disable is selected, the computer runs in Battery Optimized mode.)

2.2 Troubleshooting Flowcharts

Table 2-5
Troubleshooting Flowcharts Overview

Flowchart	Description
2.1	"Flowchart 2.1—Initial Troubleshooting"
2.2	"Flowchart 2.2—No Power, Part 1"
2.3	"Flowchart 2.3—No Power, Part 2"
2.4	"Flowchart 2.4—No Power, Part 3"
2.5	"Flowchart 2.5—No Power, Part 4"
2.6	"Flowchart 2.6—No Video, Part 1"
2.7	"Flowchart 2.7—No Video, Part 2"
2.8	"Flowchart 2.8—Nonfunctioning Docking Device (if applicable)"
2.9	"Flowchart 2.9—No Operating System (OS) Loading"
2.10	"Flowchart 2.10—No OS Loading, Hard Drive, Part 1"
2.11	"Flowchart 2.11—No OS Loading, Hard Drive, Part 2"
2.12	"Flowchart 2.12—No OS Loading, Hard Drive, Part 3"
2.13	"Flowchart 2.13—No OS Loading, Diskette Drive"

Table 2-5
Troubleshooting Flowcharts Overview (*Continued*)

Flowchart	Description
2.14	"Flowchart 2.14—No OS Loading, Optical Drive"
2.15	"Flowchart 2.15—No Audio, Part 1"
2.16	"Flowchart 2.16—No Audio, Part 2"
2.17	"Flowchart 2.17—Nonfunctioning Device"
2.18	"Flowchart 2.18—Nonfunctioning Keyboard"
2.19	"Flowchart 2.19—Nonfunctioning Pointing Device"
2.20	"Flowchart 2.20—No Network/Modem Connection"

Flowchart 2.1 – Initial Troubleshooting

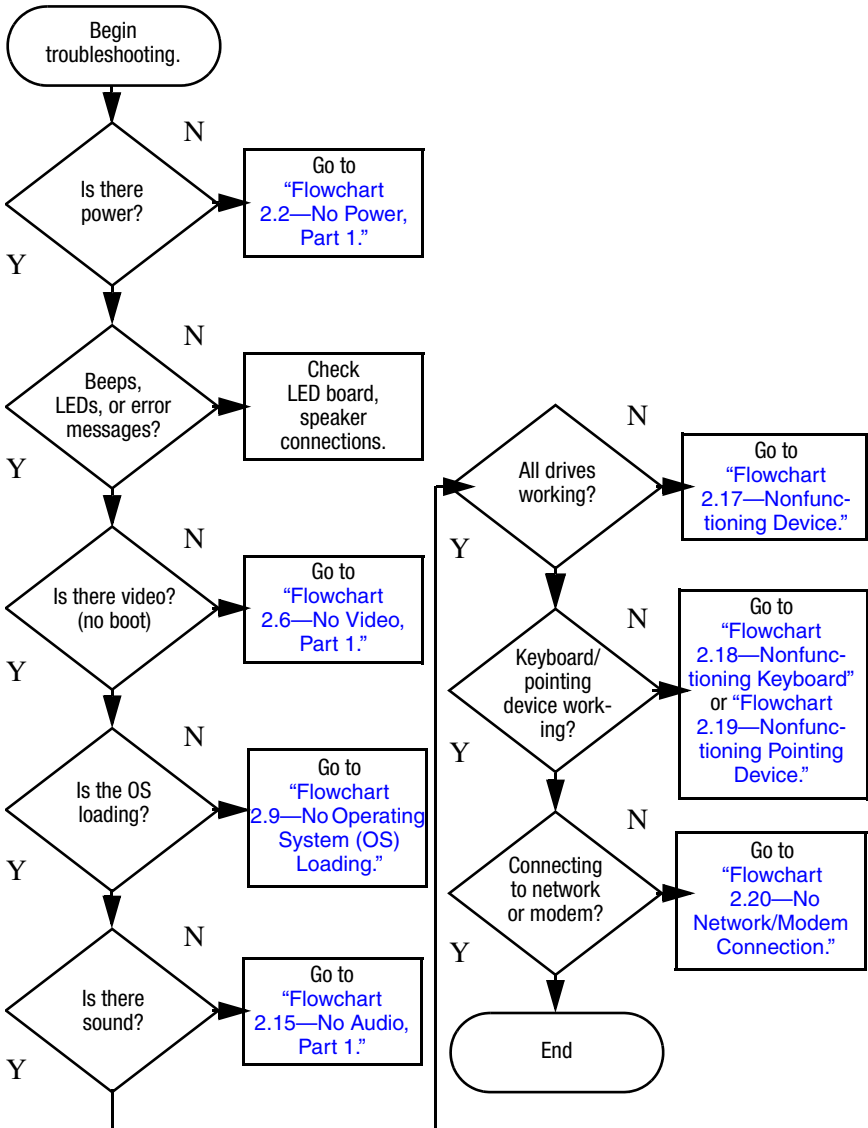

Flowchart 2.2—No Power, Part 1

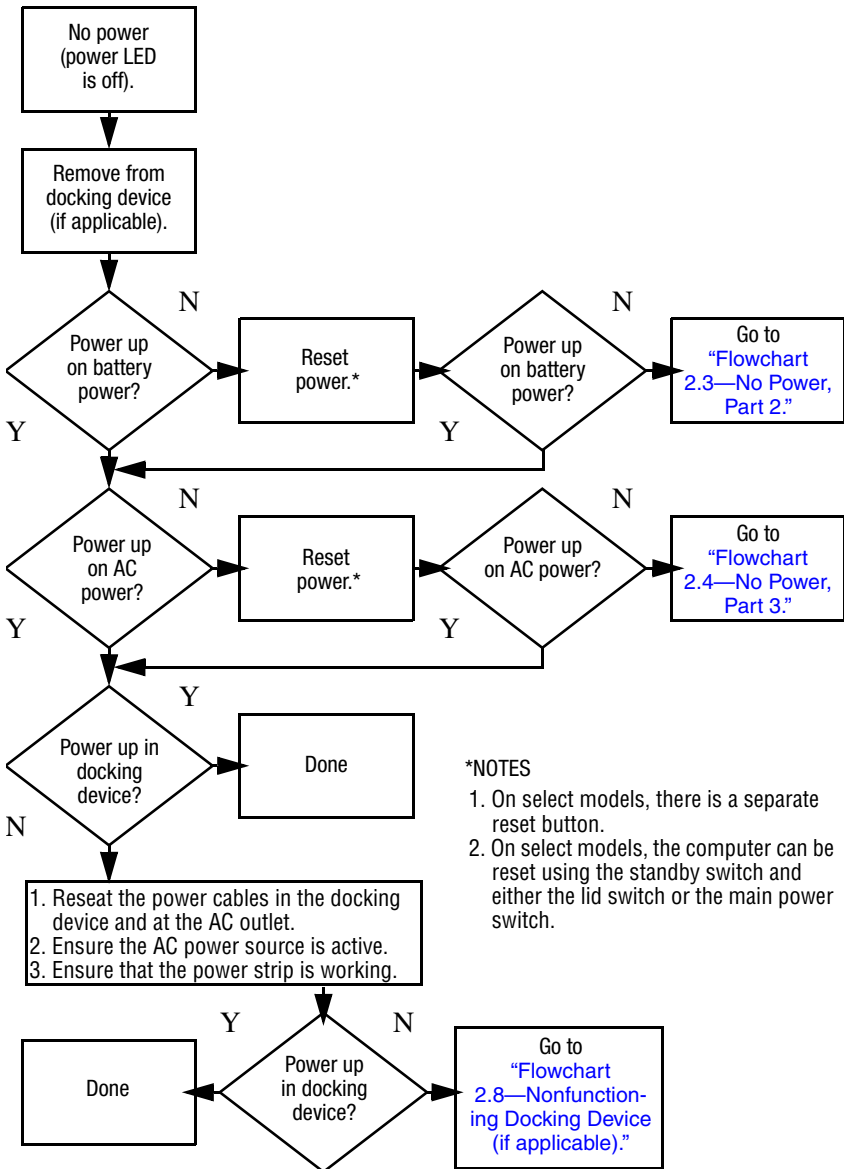

Flowchart 2.3—No Power, Part 2

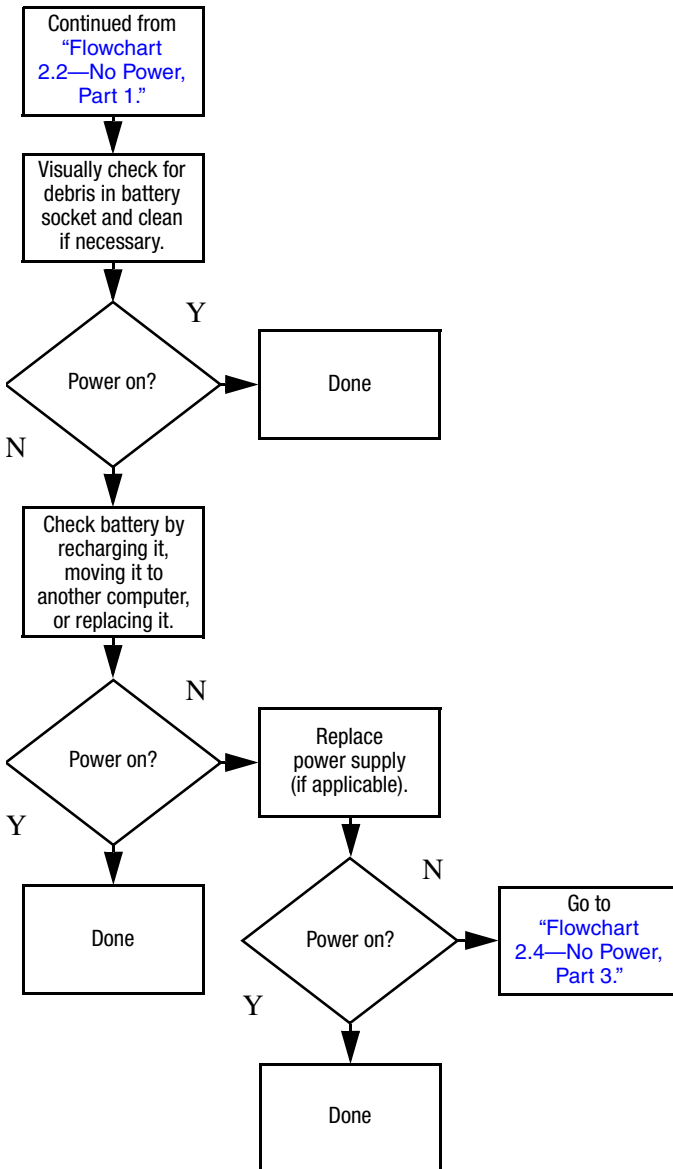

Flowchart 2.4—No Power, Part 3

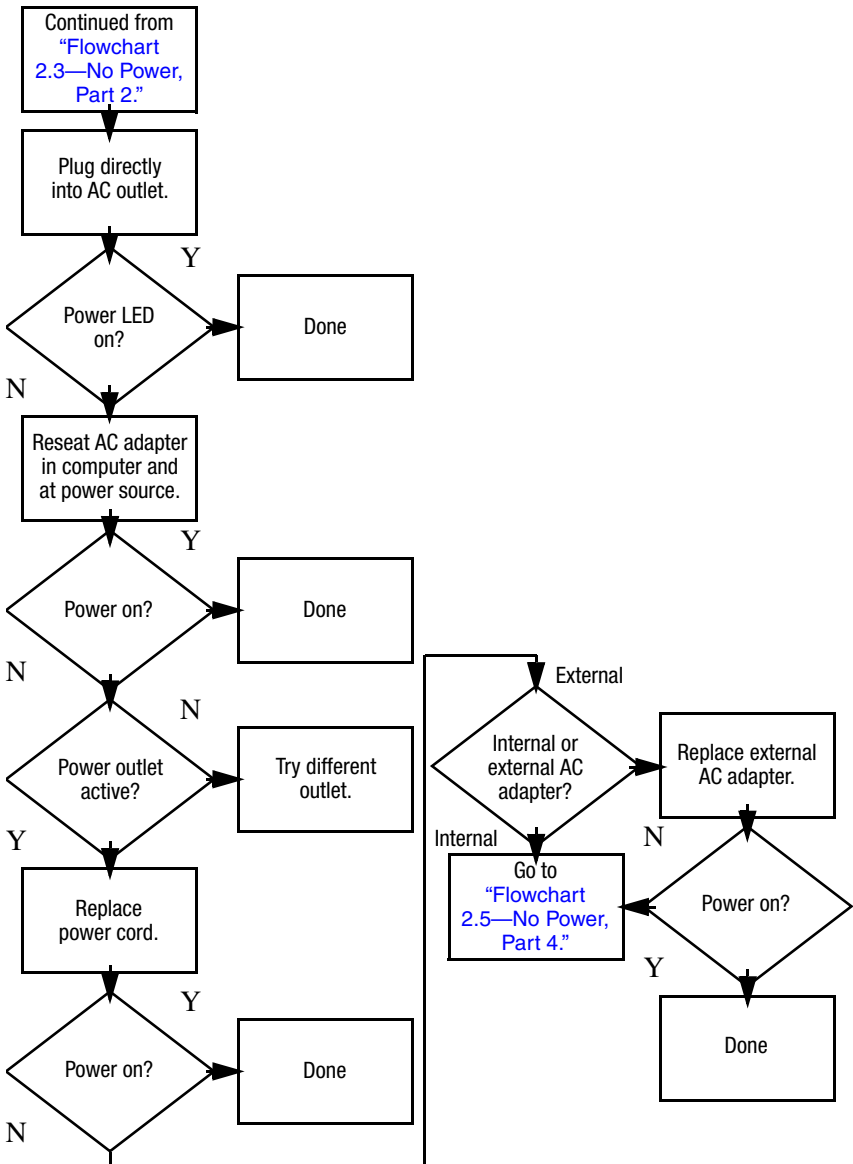

Flowchart 2.5—No Power, Part 4

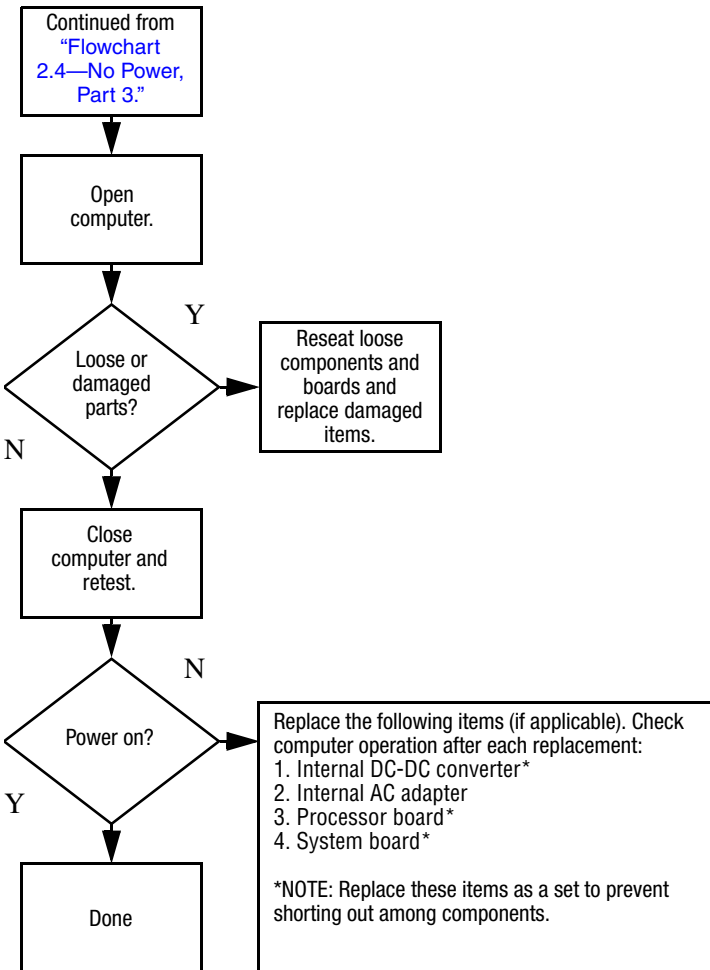

Flowchart 2.6—No Video, Part 1

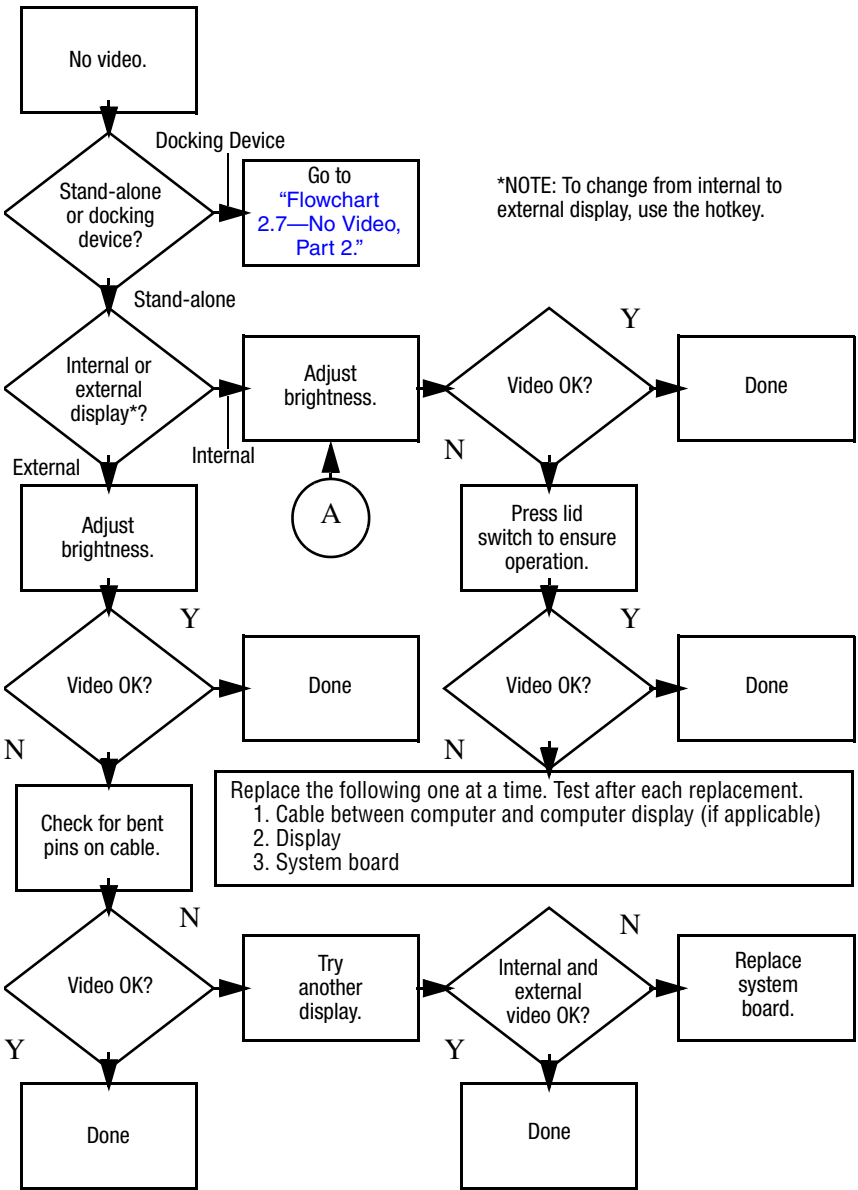

Flowchart 2.7—No Video, Part 2

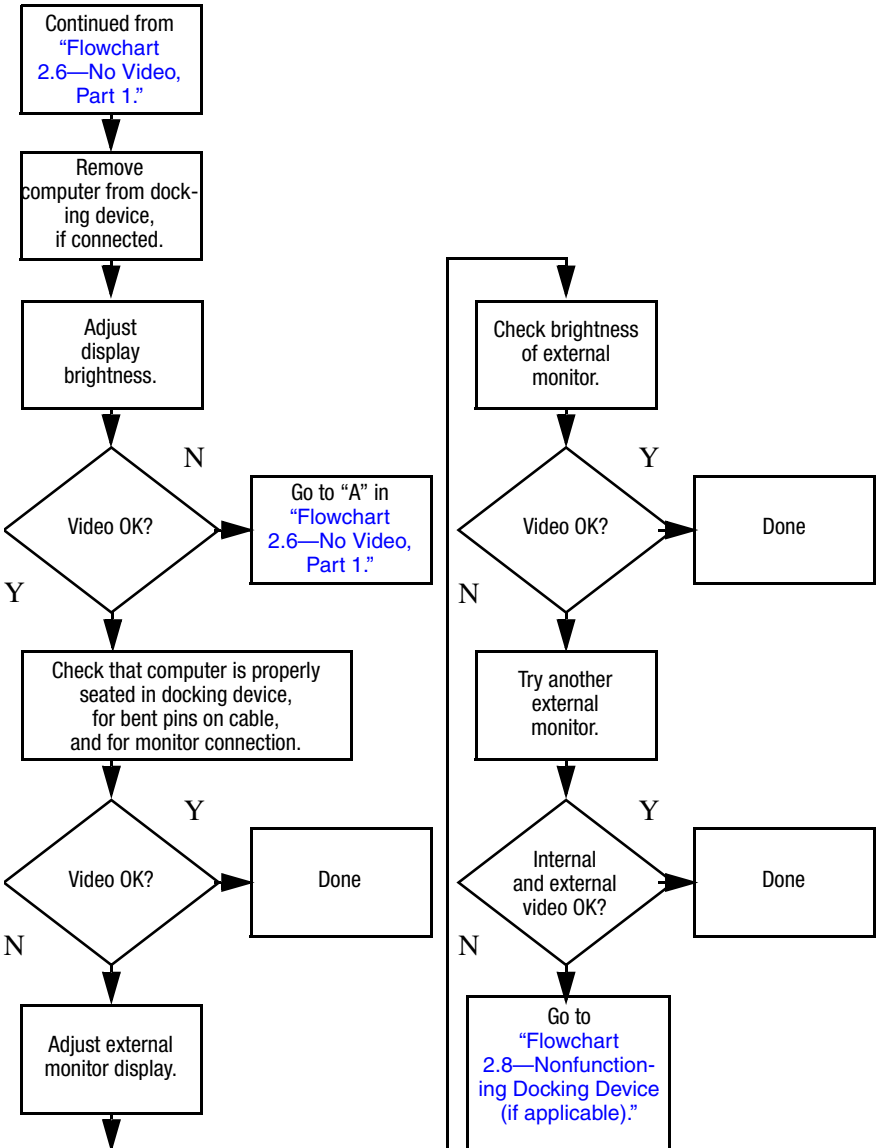

Flowchart 2.8—Nonfunctioning Docking Device (if applicable)

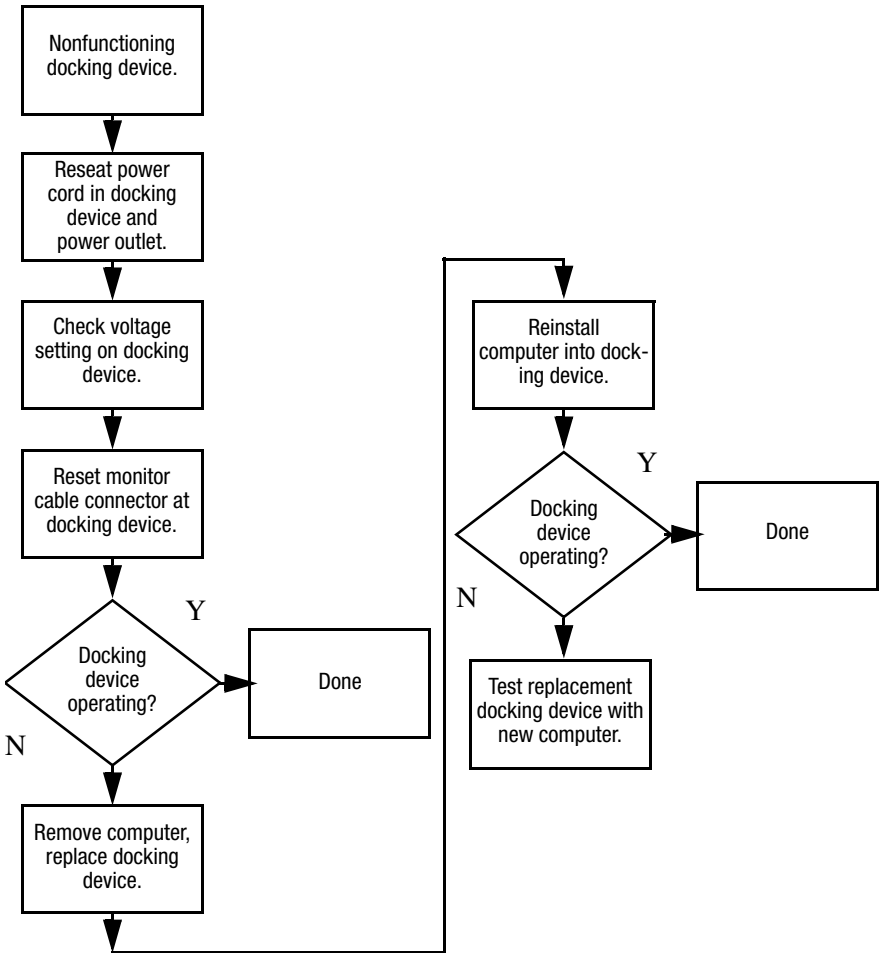

Flowchart 2.9—No Operating System (OS) Loading

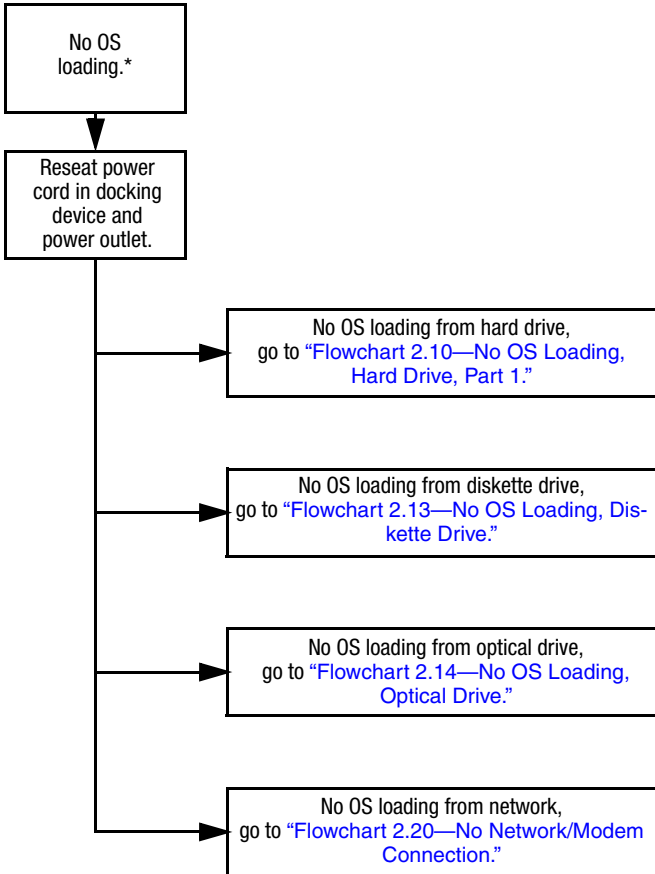

*NOTE: Before beginning troubleshooting, always check cable connections, cable ends, and drives for bent or damaged pins.

Flowchart 2.10—No OS Loading, Hard Drive, Part 1

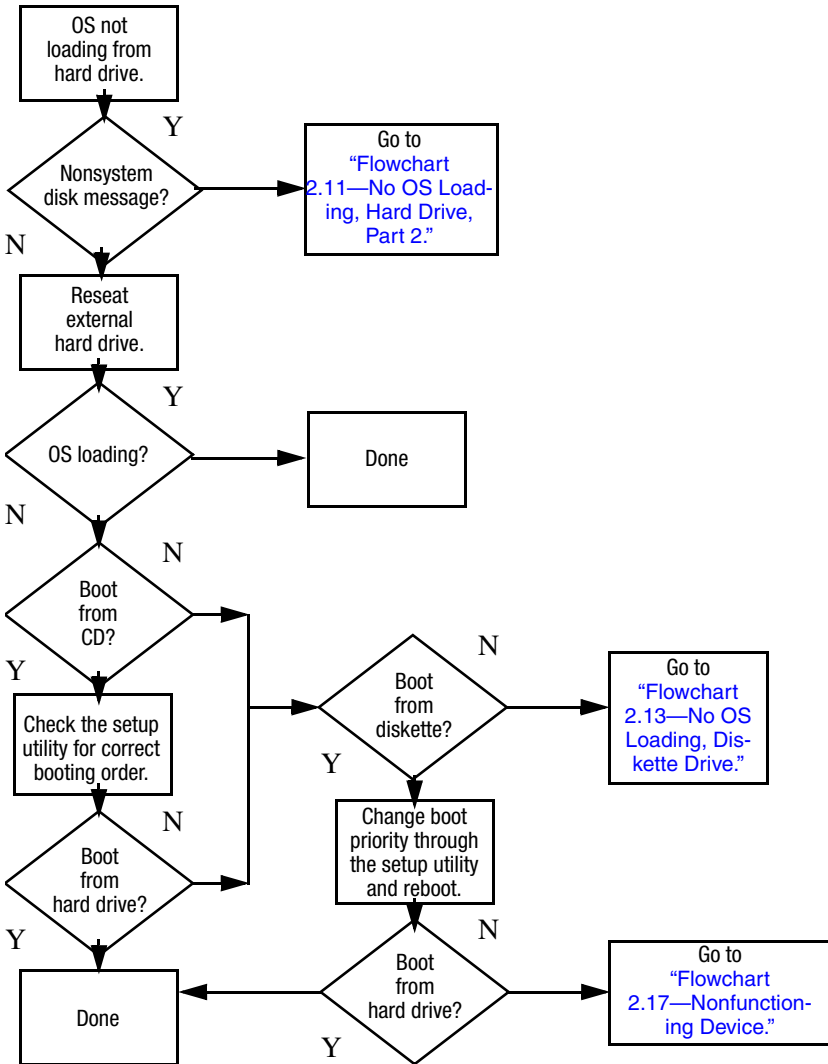

Flowchart 2.11 – No OS Loading, Hard Drive, Part 2

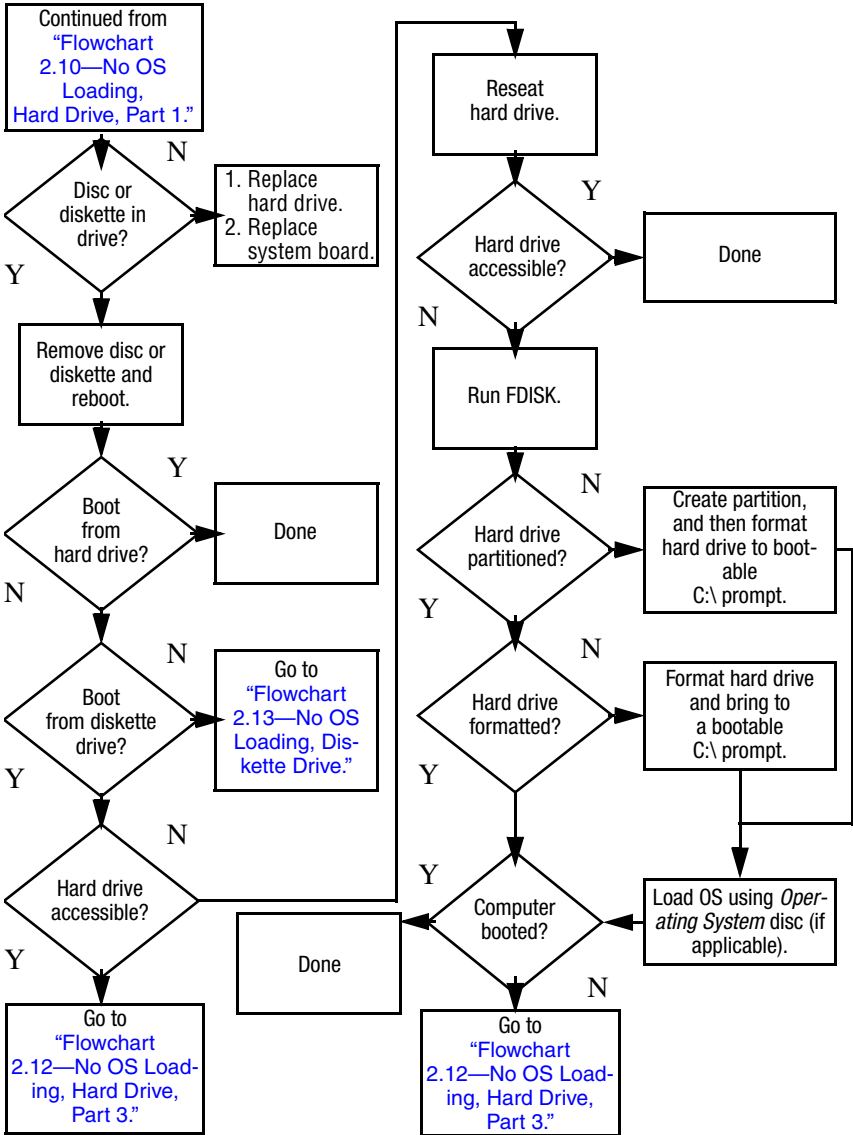

Flowchart 2.12—No OS Loading, Hard Drive, Part 3

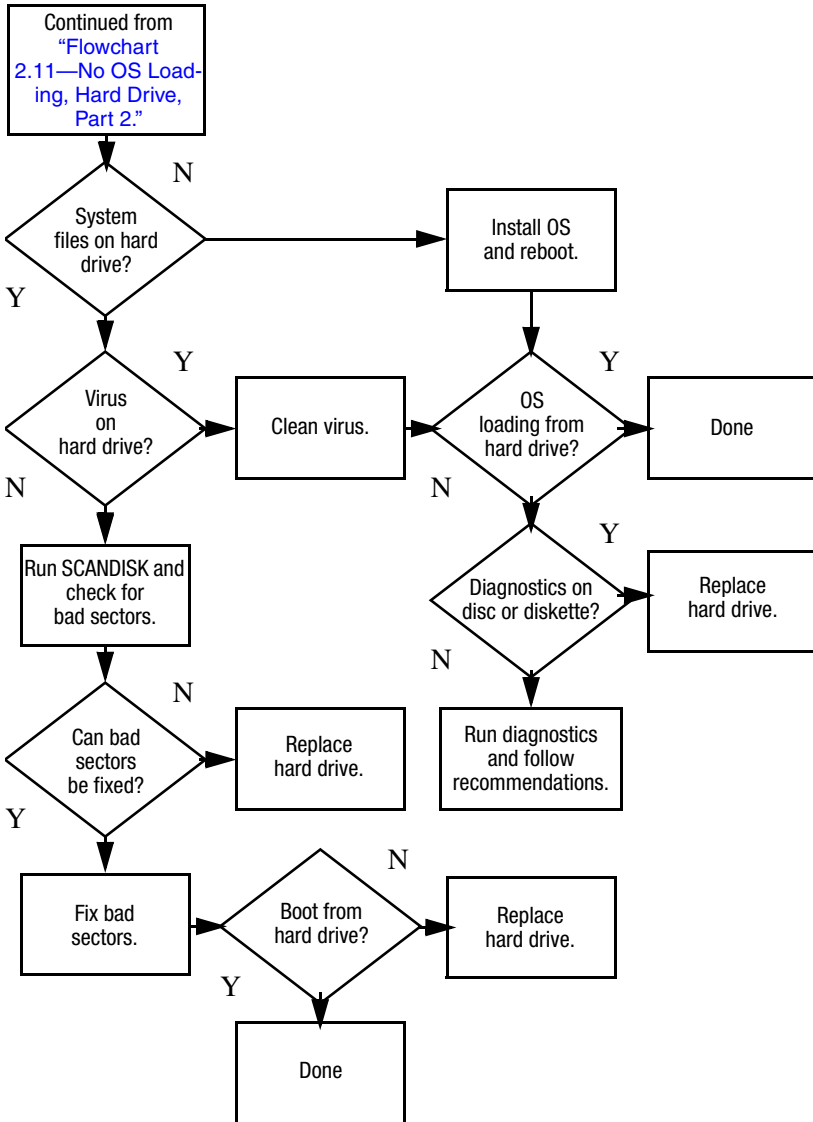

Flowchart 2.13—No OS Loading, Diskette Drive

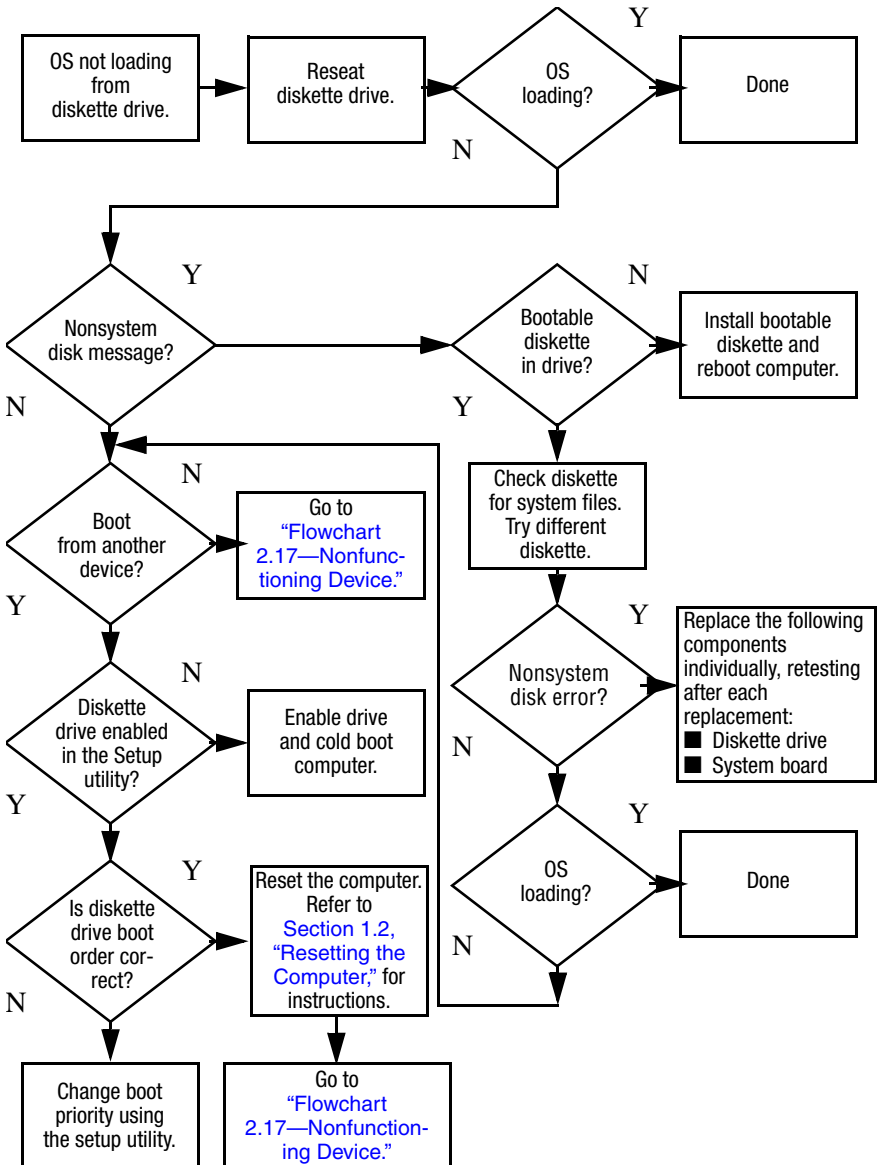

Flowchart 2.14—No OS Loading, Optical Drive

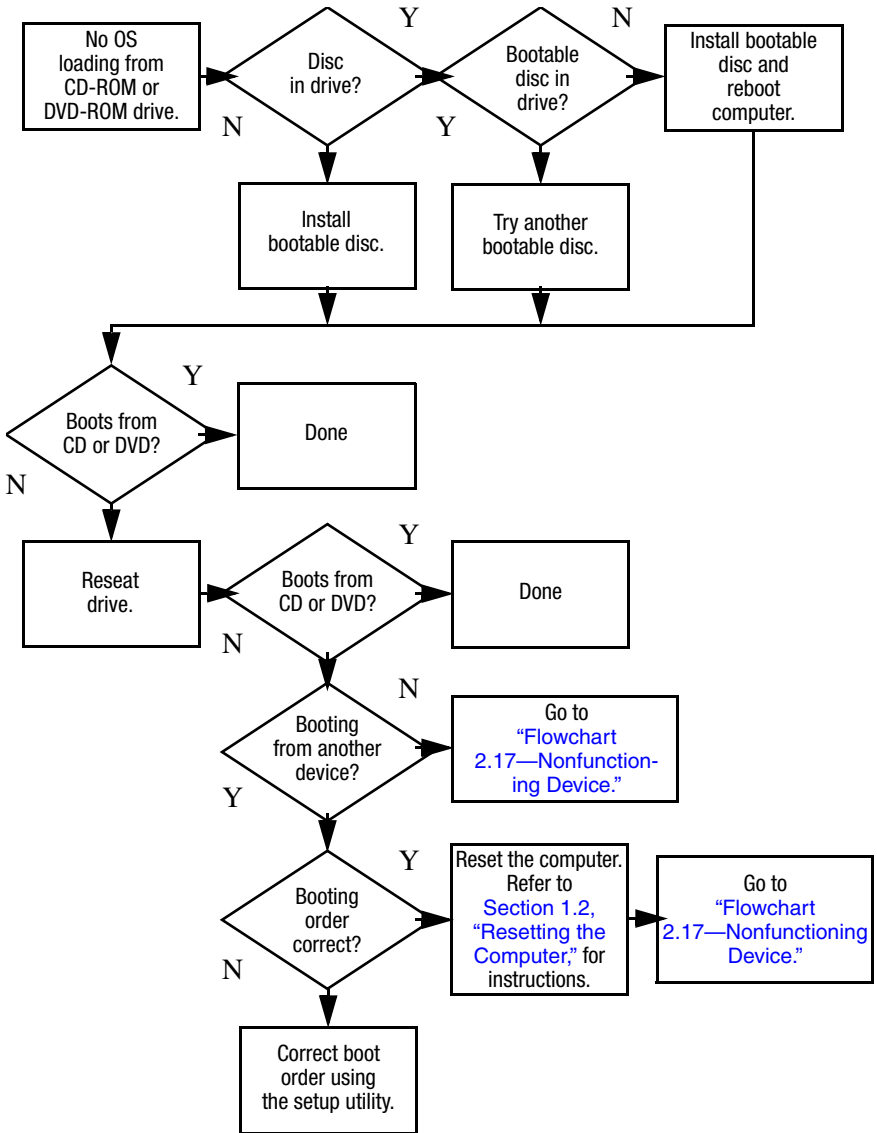

Flowchart 2.15—No Audio, Part 1

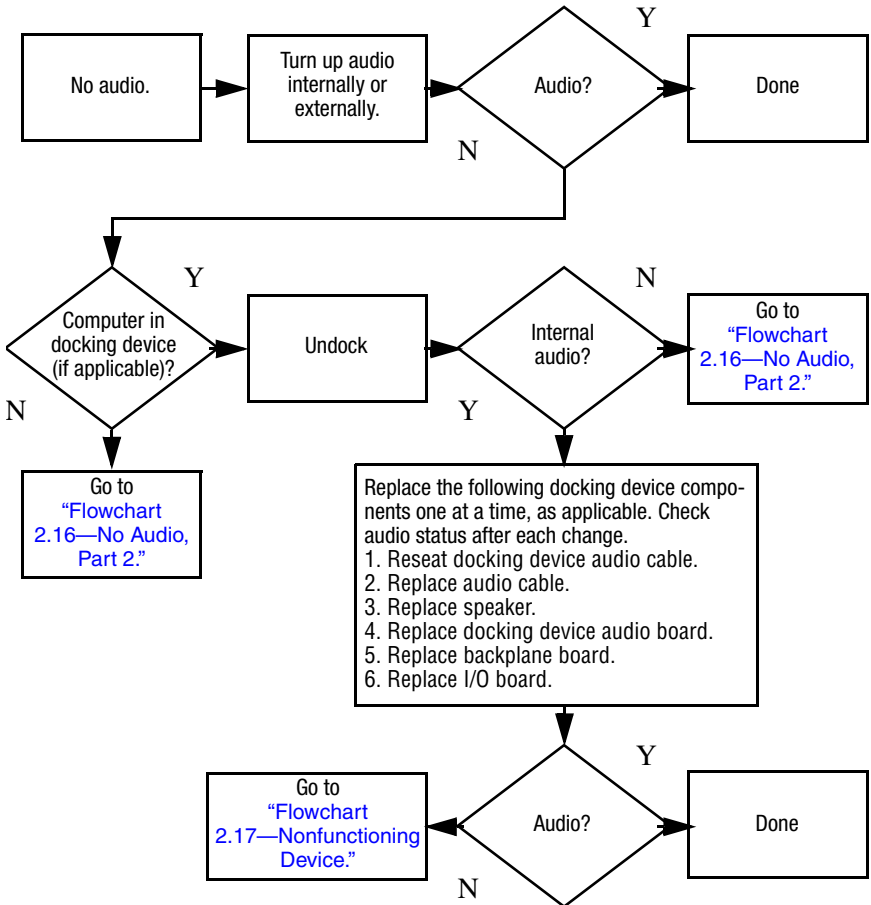

Flowchart 2.16—No Audio, Part 2

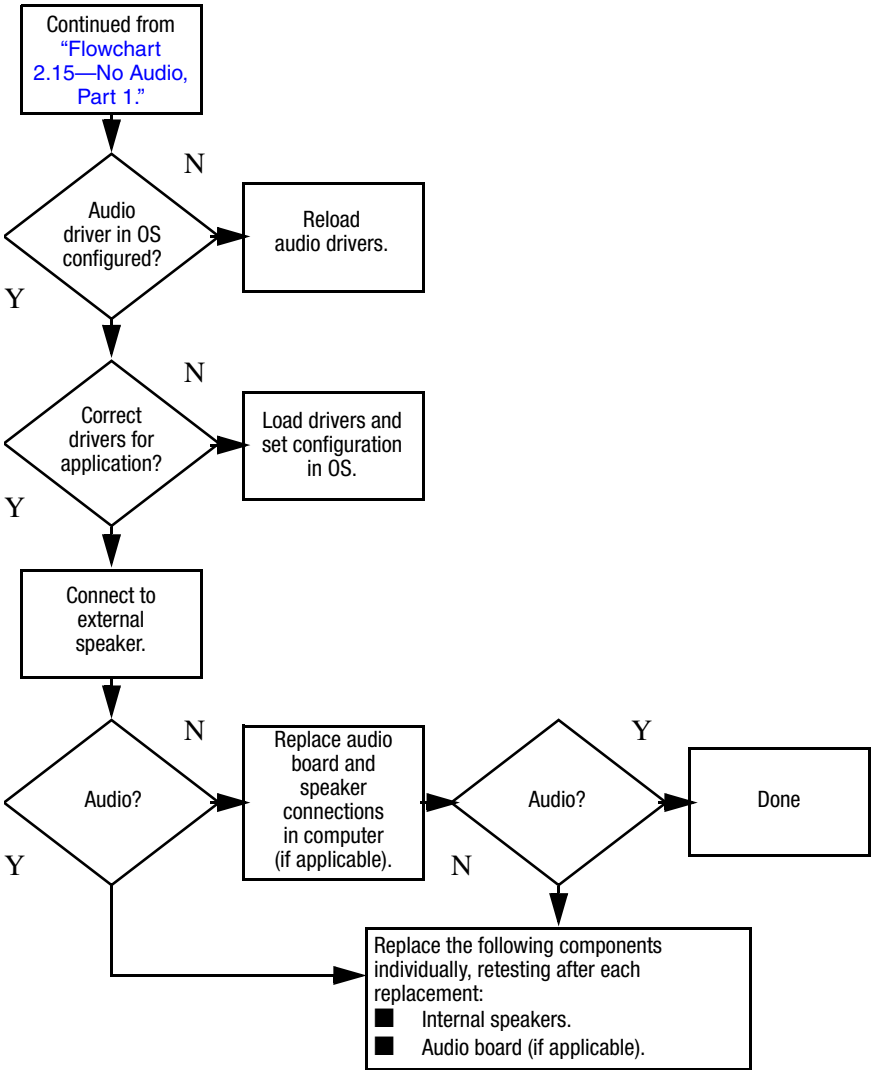

Flowchart 2.17—Nonfunctioning Device

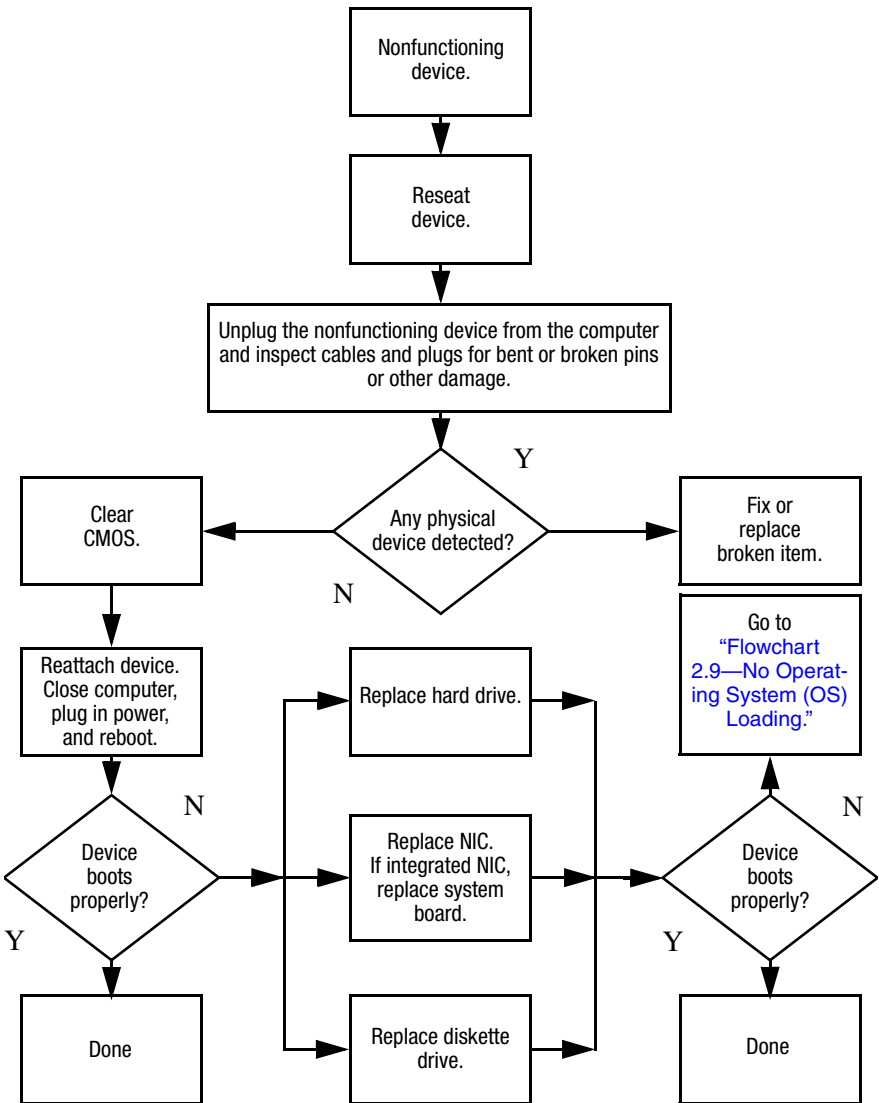

Flowchart 2.18—Nonfunctioning Keyboard

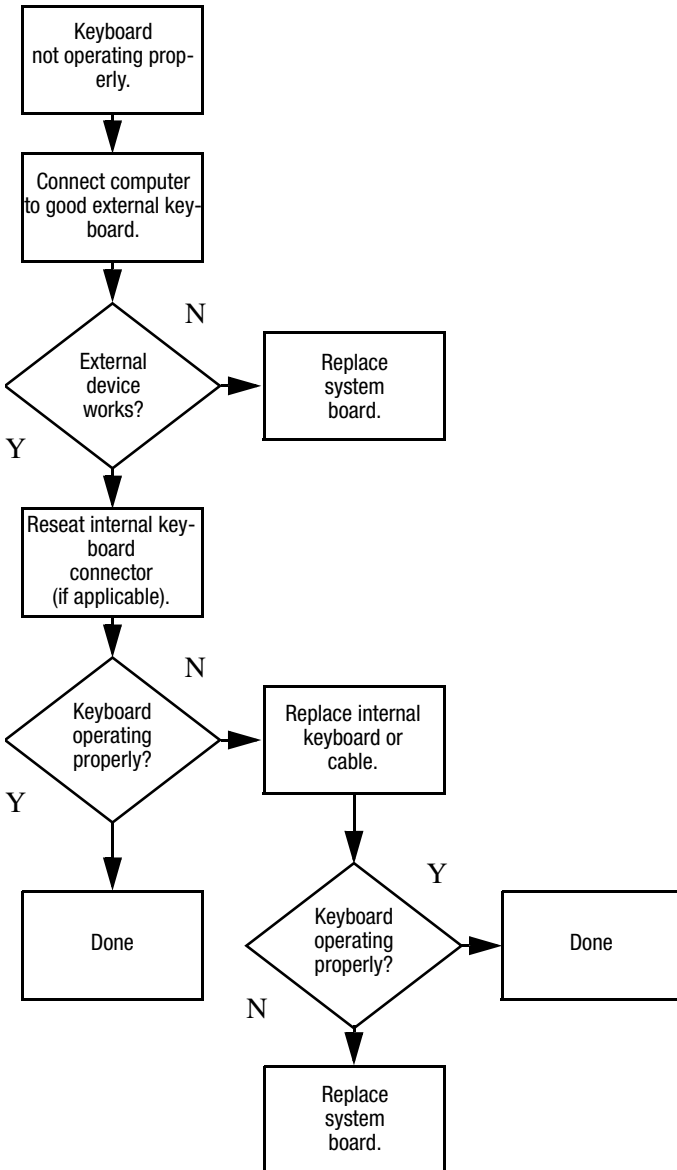

Flowchart 2.19—Nonfunctioning Pointing Device

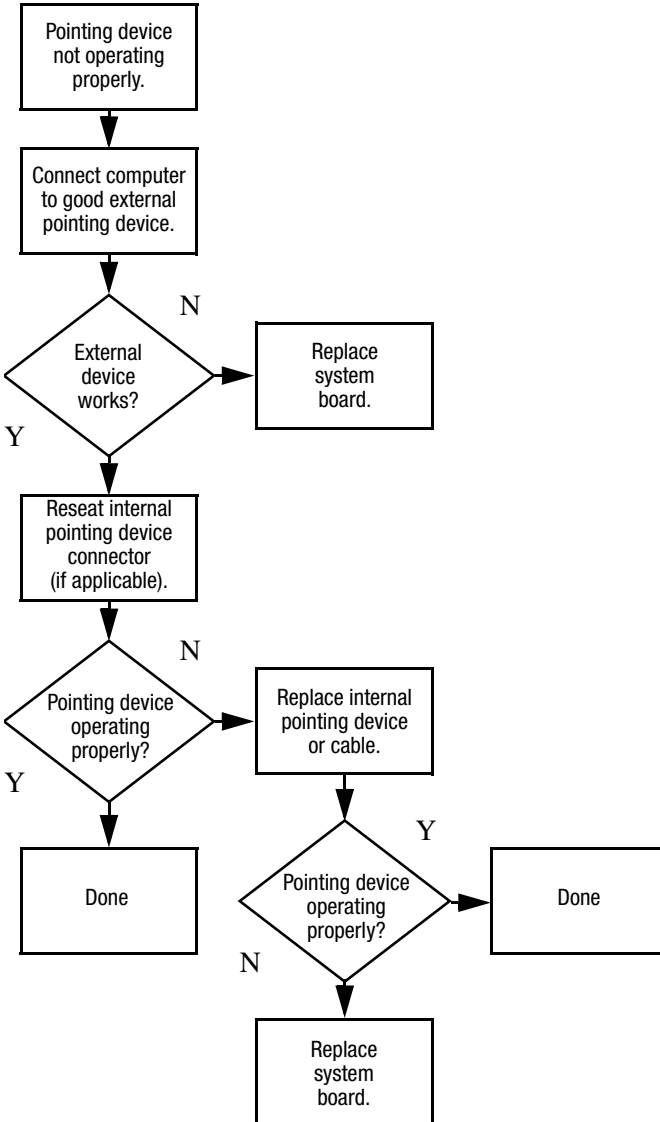

Flowchart 2.20—No Network/Modem Connection

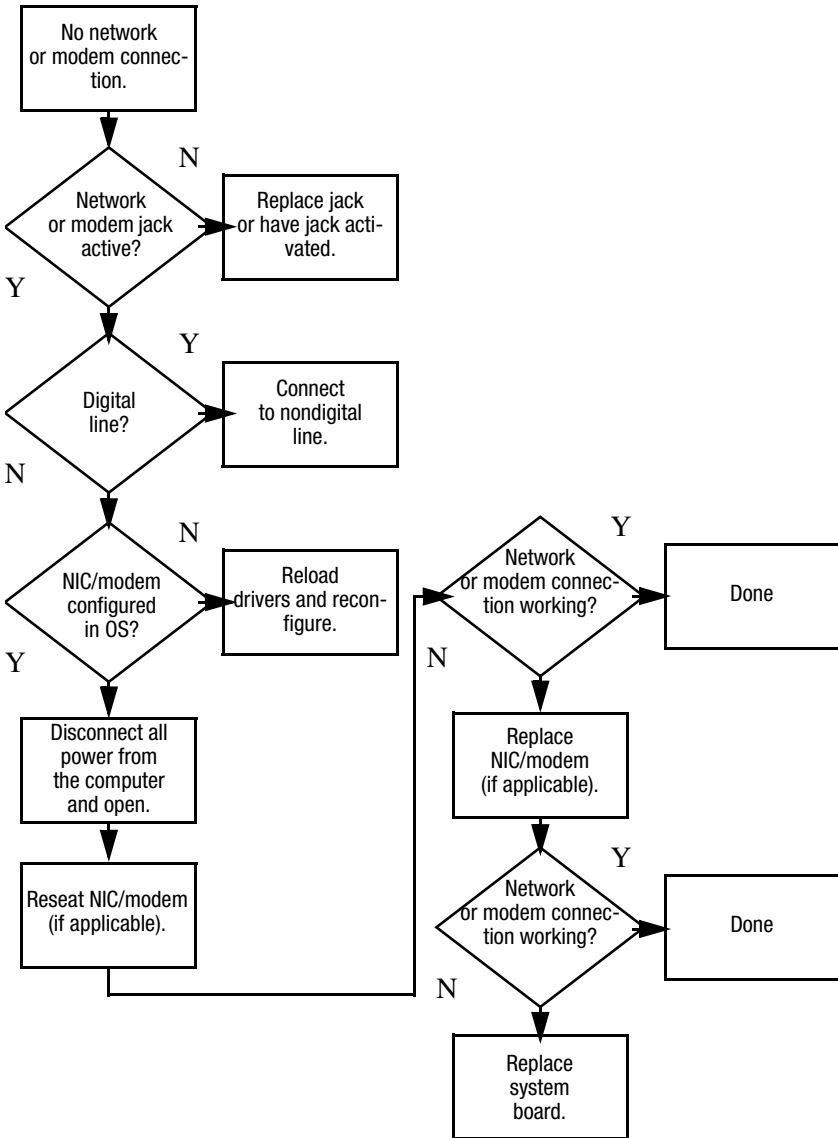

3

Illustrated Parts Catalog

This chapter provides an illustrated parts breakdown and a reference for spare part numbers.

3.1 Serial Number Location

When ordering parts or requesting information, provide the computer serial number and model number located on the bottom of the computer.

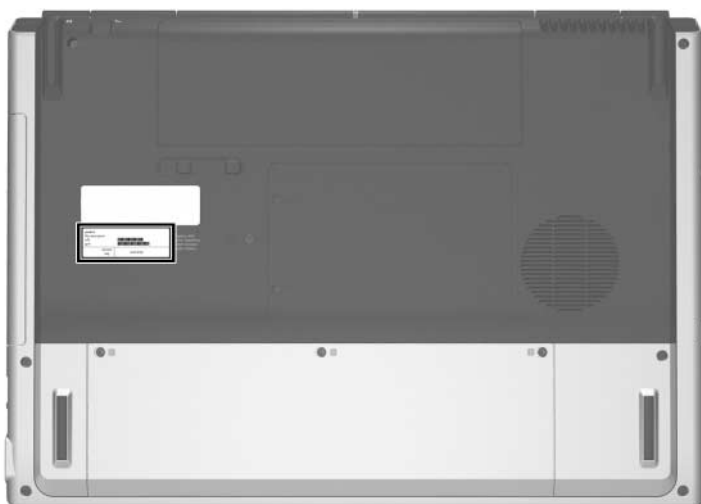

Serial Number Location

3.2 Computer Major Components

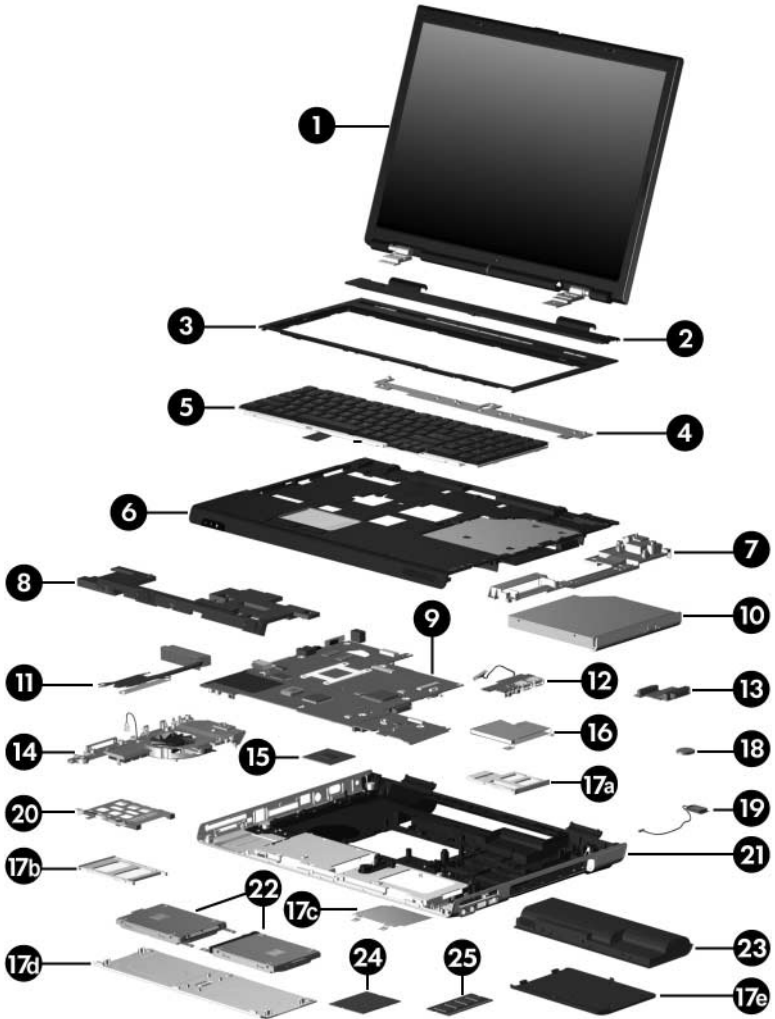

Computer Major Components

Table 3-1
Spare Parts: Computer Major Components

Item	Description	Spare Part Number
1	Display assemblies (include display cable, wireless antenna boards, and antenna cables)	
	17-inch, WSXGA+ with BrightView	403797-001
	17-inch, WXGA+ with BrightView	403796-001
	 Refer to Section 3.3, "Display Assembly Subcomponents," for display assembly internal component spare part number information.	
2	Switch cover (includes LED board and LED board cable)	403817-001
3	Keyboard assembly frame	403818-001
4	LED board (includes LED board cable)	403833-001
5	Keyboards	
	France 403809-051	Spain 403809-071
	French Canada 403809-121	Sweden and 403809-101
	Germany 403809-041	Finland
	Italy 403809-061	United Kingdom 403809-031
	Norway 403809-091	United States 403809-001

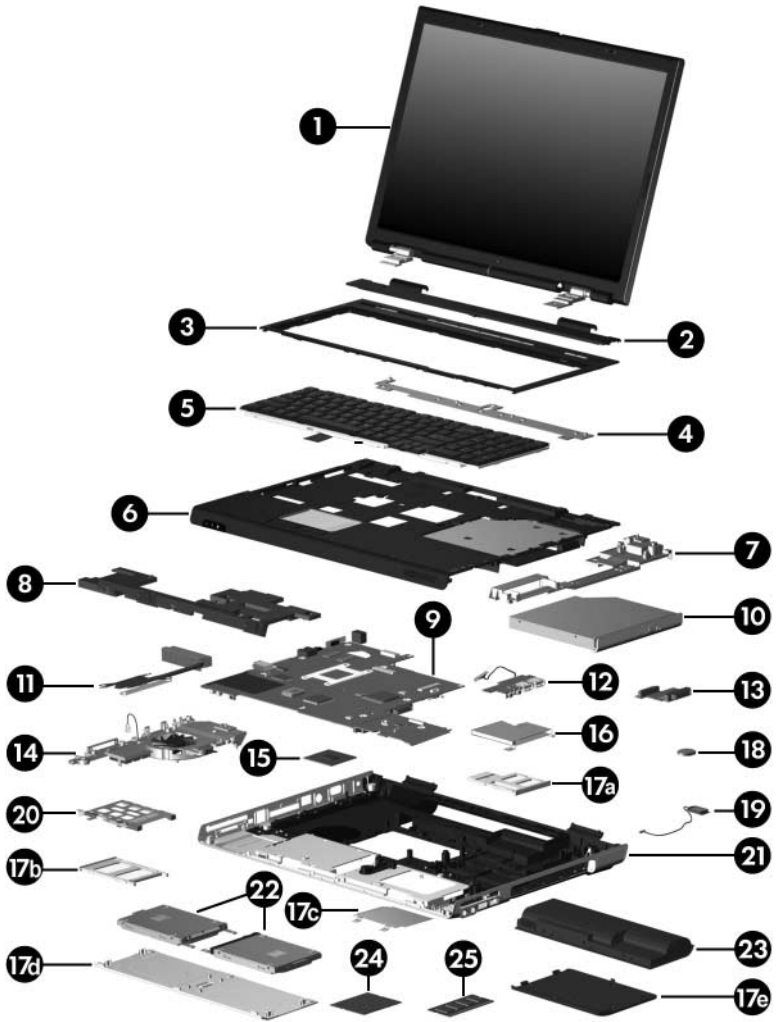

Computer Major Components

Table 3-1**Spare Parts: Computer Major Components (Continued)**

Item	Description	Spare Part Number
6	Top cover (includes TouchPad)	403822-001
7	Bracket Kit , includes: Display hinge support bracket Not illustrated: Optical drive bracket (also included with optical drive spare part kits) Hard drive bracket (also included with hard drive spare part kits) Expansion port 2 bracket TouchPad bracket (also included with top cover spare part kits)	403816-001
8	Speakers	403825-001
9	System board	403790-001
10	Optical drives	
	DVD±RW and CD-RW Double Layer Combo Drive with LightScribe	403807-001
	DVD±RW and CD-RW Double Layer Combo Drive	403806-001
	DVD/CD-RW Combo Drive	403805-001
11	Heat sink (includes thermal paste)	403827-001
12	USB board (includes USB board and USB board cable)	403830-001
13	Optical drive connector board	403829-001
14	Fan assembly	403826-001

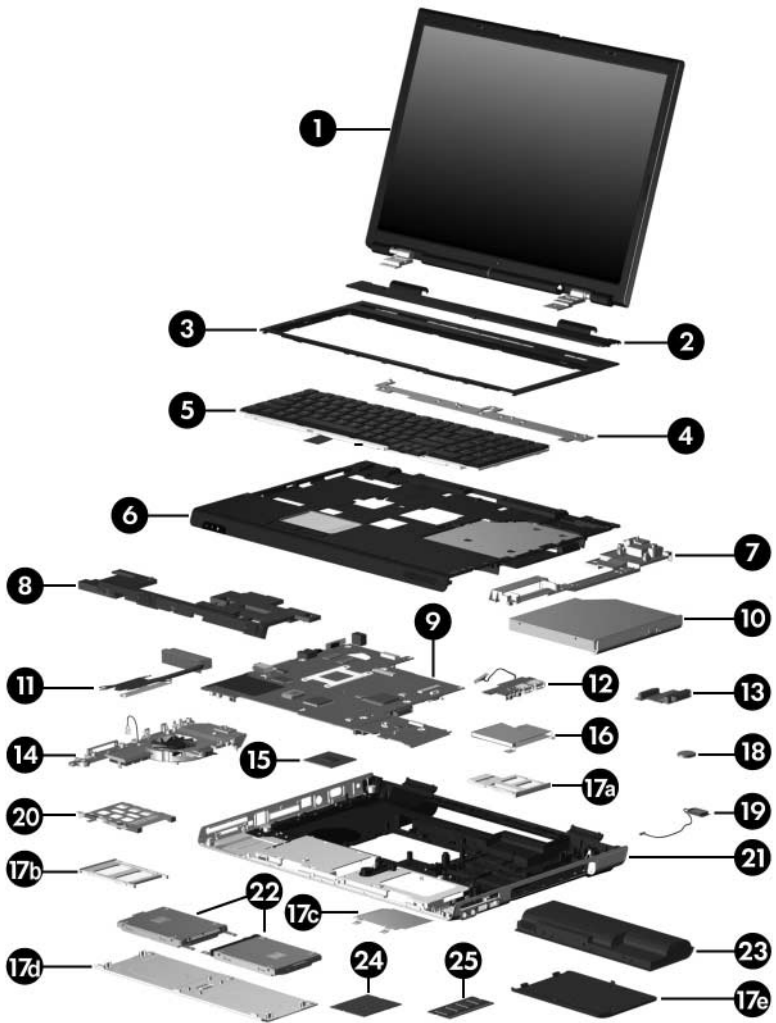

Computer Major Components

Table 3-1**Spare Parts: Computer Major Components (Continued)**

Item	Description	Spare Part Number		
15	Processors (include thermal paste)			
	AMD Turion 64 ML-40 (2.2-GHz)	393579-001		
	AMD Turion 64 ML-37 (2.0-GHz)	393578-001		
	AMD Turion 64 ML-32 (1.8-GHz)	395744-001		
	AMD Turion 64 ML-30 (1.6-GHz)	395743-001		
16	ExpressCard assembly	403828-001		
	Plastics Kit	403812-001		
	Includes:			
17a	ExpressCard slot bezel			
17b	PC Card slot bezel			
17c	Memory shield			
17d	Hard drive cover (includes 3 captive screws)			
17e	Memory/Mini PCI module compartment cover (includes 2 captive screws)			
	Computer feet (not illustrated)			
18	RTC battery	403819-001		
19	Bluetooth® module (includes Bluetooth module cable)	397922-001		
20	PC Card assembly	403835-001		
21	Base enclosure	403824-001		
22	Hard drives (include frame and connector)			
	7200 rpm, 100-GB	405938-001	4200-rpm, 120-GB	405939-001
	5400 rpm, 80-GB	403803-001	4200-rpm, 100-GB	403804-001
			4200-rpm, 60-GB	405937-001

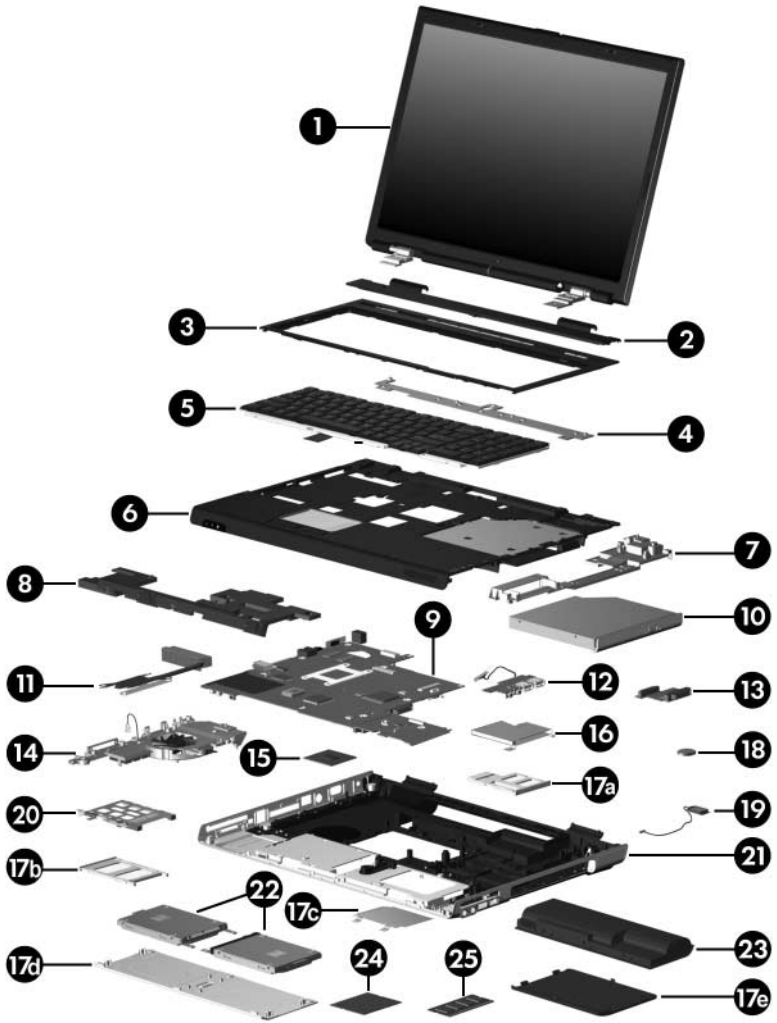

Computer Major Components

Table 3-1**Spare Parts: Computer Major Components (Continued)**

Item	Description	Spare Part Number
23	8-cell, 4.4-hour battery pack	403808-001
24	Mini PCI communications modules	
	802.11a/b/g wireless local access network (WLAN) module for use in North America	403791-001
	802.11a/b/g WLAN module for use in the rest of the world	403792-001
	802.11b/g WLAN module for use in North America	392557-001
	802.11b/g WLAN module for use in the rest of the world	392557-002
25	Memory modules	
	1024 MB	403800-001
	512 MB	403799-001
	256 MB	403573-001

3.3 Display Assembly Subcomponents



Table 3-2
Display Assembly Subcomponent
Spare Part Number Information

Item	Description	
	Display Plastics Kit , includes:	403881-001
1a	■ Display bezel	
1b	■ Display enclosure	
	■ Display release latch actuator and hooks (not illustrated)	
2	Display Hinge Kit	403884-001
3	Display inverter board	403831-001
4	Display Panel Kit (includes display panel cable)	403885-001
5	Wireless Antenna Kit (includes cable and transceivers)	403882-001
	Display Label Kit (not illustrated)	403887-001
	Display Screw Kit (not illustrated), includes:	403886-001
	■ Phillips PM2.5×7.0 screws	
	■ Phillips PM2.5×5.0 screws	
	■ Rubber screw covers	

3.4 Plastics Kit



Table 3-3
Plastics Kit
Spare Part Number Information

Item	Description	Spare Part Number
	Plastics Kit , includes:	403812-001
1	Memory/Mini PCI module compartment cover (includes 2 captive screws, secured by C-clips)	
2	Hard drive cover (includes 3 captive screws, secured by C-clips)	
3	Computer feet (6)	
4	ExpressCard slot bezel	
5	PC Card slot bezel	

3.5 Cable Kit

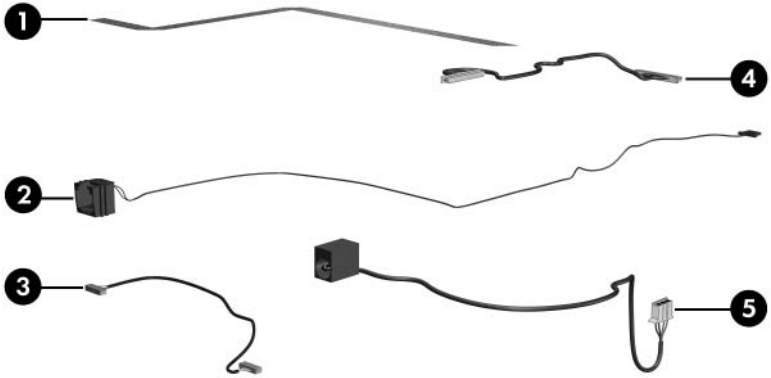

Table 3-4
Cable Kit
Spare Part Number Information

Item	Description	Spare Part Number
	Cable Kit , includes:	403814-001
1	TouchPad cable	
2	Modem connector cable	
3	Bluetooth module cable	
4	USB board cable	
5	Power connector cable	

3.6 Mass Storage Devices



Table 3-5
Mass Storage Devices
Spare Part Number Information

Item	Description	Spare Part Number
1	Hard drives (include frame and connector)	
	7200 rpm, 100-GB 405938-001 4200-rpm, 120-GB	405939-001
	5400 rpm, 80-GB 403803-001 4200-rpm, 100-GB	403804-001
		4200-rpm, 60-GB 405937-001
2	Optical drives	
	DVD±RW and CD-RW Double Layer Combo Drive with LightScribe	403807-001
	DVD±RW and CD-RW Double Layer Combo Drive	403806-001
	DVD/CD-RW Combo Drive	403805-001
	USB digital drive (not illustrated)	364727-001

3.7 Miscellaneous (Not Illustrated)

Table 3-6
Miscellaneous (Not Illustrated)
Spare Part Information

Description	Spare Part Number
All-in-one media cable	375759-001
Audio Y-cable 2	379452-001
Power supply, 65 watt	403810-001
Power cords	
For use in:	
Canada, French Canada, and the United States	403811-001
France, Germany, and Spain	403811-021
The United Kingdom	403811-031
Italy	403811-061
HP remote control	371694-001
Screw Kit (includes the following screws; refer to Appendix C, "Screw Listing," for more information on specifications and usage)	403813-001
<ul style="list-style-type: none"> ■ Phillips PM3.0×4.0 screw ■ Phillips PM2.5×13.0 screw ■ Phillips PM2.5×9.0 screw ■ Phillips PM2.5×7.0 screw ■ Black Phillips PM2.5×6.0 screw 	<ul style="list-style-type: none"> ■ Silver Phillips PM2.5×6.0 screw ■ Phillips PM2.5×4.0 screw ■ Phillips PM2.0×4.0 screw ■ Slotted M1.5×9.0 screw
USB travel mouse	309674-001
USB digital drive	364727-001
Wired headset with volume control	371693-001

3.8 Sequential Part Number Listing

Table 3-7
Sequential Part Number Listing

Spare Part Number	Description
309674-001	USB travel mouse
364727-001	USB digital drive
371693-001	Wired headset with volume control
371694-001	HP remote control
375759-001	All-in-one media cable
379452-001	Audio Y-cable 2
392557-001	802.11b/g WLAN Mini PCI communications module for use in North America
392557-002	802.11b/g WLAN Mini PCI communications module for use in the rest of the world
393578-001	AMD Turion 64 ML-37 (2.0-GHz) processor (includes thermal paste)
393579-001	AMD Turion 64 ML-40 (2.2-GHz) processor (includes thermal paste)
395743-001	AMD Turion 64 ML-30 (1.6-GHz) processor (includes thermal paste)
395744-001	AMD Turion 64 ML-32 (1.8-GHz) processor (includes thermal paste)
397922-001	Bluetooth wireless module (includes Bluetooth module cable)
403573-001	256-MB memory module
403790-001	System board
403791-001	802.11a/b/g WLAN Mini PCI communications module for use in North America

Table 3-7
Sequential Part Number Listing (*Continued*)

Spare Part Number	Description
403792-001	802.11a/b/g WLAN Mini PCI communications module for use in the rest of the world
403796-001	17-inch, WXGA+ with BrightView display assembly (includes display cable, wireless antenna boards, and antenna cables)
403797-001	17-inch, WSXGA+ with BrightView display assembly (includes display cable, wireless antenna boards, and antenna cables)
403799-001	512-MB memory module
403800-001	1024-MB memory module
403803-001	5400 rpm, 80-GB hard drive (includes frame and connector)
403804-001	4200-rpm, 100-GB hard drive (includes frame and connector)
403805-001	DVD/CD-RW Combo Drive
403806-001	DVD±RW and CD-RW Double Layer Combo Drive
403807-001	DVD±RW and CD-RW Double Layer Combo Drive with LightScribe
403808-001	8-cell, 4.4-hour battery pack
403809-001	Keyboard for use in the United States
403809-031	Keyboard for use in the United Kingdom
403809-041	Keyboard for use in France
403809-051	Keyboard for use in Germany
403809-061	Keyboard for use in Italy
403809-071	Keyboard for use in Spain
403809-091	Keyboard for use in Norway
403809-101	Keyboard for use in Sweden and Finland
403809-121	Keyboard for use in French Canada

Table 3-7
Sequential Part Number Listing (*Continued*)

Spare Part Number	Description
403810-001	Power supply, 65 watt
403811-001	Power cord for use in the United States
403811-021	Power cord for use Internationally
403811-031	Power cord for use in the United Kingdom
403811-061	Power cord for use in Italy
403812-001	Plastics Kit
403813-001	Screw Kit
403814-001	Cable Kit
403816-001	Bracket Kit
403817-001	Switch cover (includes LED board and LED board cable)
403818-001	Keyboard assembly frame
403819-001	RTC battery
403822-001	Top cover (includes TouchPad)
403824-001	Base enclosure
403825-001	Speakers
403826-001	Fan assembly
403827-001	Heat sink (includes thermal paste)
403828-001	ExpressCard assembly
403829-001	Optical drive connector board
403830-001	USB board (includes USB board and USB board cable)
403831-001	Display inverter board
403833-001	LED board (includes LED board cable)

Table 3-7
Sequential Part Number Listing (*Continued*)

Spare Part Number	Description
403835-001	PC Card assembly
403881-001	Display Plastics Kit
403882-001	Wireless Antenna Kit
403884-001	Display Hinge Kit
403885-001	Display Panel Kit
403886-001	Display Screw Kit
403887-001	Display Label Kit
405937-001	4200-rpm, 60-GB hard drive (includes frame and connector)
405938-001	7200 rpm, 100-GB hard drive (includes frame and connector)
405939-001	4200-rpm, 120-GB hard drive (includes frame and connector)

Removal and Replacement Preliminaries

This chapter provides essential information for proper and safe removal and replacement service.

4.1 Tools Required

You will need the following tools to complete the removal and replacement procedures:

- Magnetic screwdriver
- Phillips P0 screwdriver
- Flat-bladed screwdriver
- Tool kit—includes connector removal tool, loopback plugs, and case utility tool

4.2 Service Considerations

The following sections include some of the considerations that you should keep in mind during disassembly and assembly procedures.



As you remove each subassembly from the computer, place the subassembly (and all accompanying screws) away from the work area to prevent damage.

Plastic Parts

Using excessive force during disassembly and reassembly can damage plastic parts. Use care when handling the plastic parts. Apply pressure only at the points designated in the maintenance instructions.

Cables and Connectors



CAUTION: When servicing the computer, ensure that cables are placed in their proper locations during the reassembly process. Improper cable placement can damage the computer.

Cables must be handled with extreme care to avoid damage. Apply only the tension required to unseat or seat the cables during removal and insertion. Handle cables by the connector whenever possible. In all cases, avoid bending, twisting, or tearing cables. Ensure that cables are routed in such a way that they cannot be caught or snagged by parts being removed or replaced. Handle flex cables with extreme care; these cables tear easily.

4.3 Preventing Damage to Removable Drives

Removable drives are fragile components that must be handled with care. To prevent damage to the computer, damage to a removable drive, or loss of information, observe the following precautions:

- Before removing or inserting a hard drive, shut down the computer. If you are unsure whether the computer is off or in hibernation, turn the computer on, and then shut it down through the operating system.
- Before removing a diskette drive or optical drive, ensure that a diskette or disc is not in the drive and ensure that the optical drive tray is closed.
- Before handling a drive, ensure that you are discharged of static electricity. While handling a drive, avoid touching the connector.
- Handle drives on surfaces covered with at least one inch of shock-proof foam.
- Avoid dropping drives from any height onto any surface.
- After removing a hard drive, an optical drive, or a diskette drive, place it in a static-proof bag.
- Avoid exposing a hard drive to products that have magnetic fields, such as monitors or speakers.
- Avoid exposing a drive to temperature extremes or liquids.
- If a drive must be mailed, place the drive in a bubble pack mailer or other suitable form of protective packaging and label the package “FRAGILE: Handle With Care.”

4.4 Preventing Electrostatic Damage

Many electronic components are sensitive to electrostatic discharge (ESD). Circuitry design and structure determine the degree of sensitivity. Networks built into many integrated circuits provide some protection, but in many cases, the discharge contains enough power to alter device parameters or melt silicon junctions.

A sudden discharge of static electricity from a finger or other conductor can destroy static-sensitive devices or microcircuitry. Often the spark is neither felt nor heard, but damage occurs.

An electronic device exposed to electrostatic discharge may not be affected at all and can work perfectly throughout a normal cycle. Or the device may function normally for a while, then degrade in the internal layers, reducing its life expectancy.

4.5 Packaging and Transporting Precautions

Use the following grounding precautions when packaging and transporting equipment:

- To avoid hand contact, transport products in static-safe containers, such as tubes, bags, or boxes.
- Protect all electrostatic-sensitive parts and assemblies with conductive or approved containers or packaging.
- Keep electrostatic-sensitive parts in their containers until the parts arrive at static-free workstations.
- Place items on a grounded surface before removing items from their containers.
- Always be properly grounded when touching a sensitive component or assembly.
- Store reusable electrostatic-sensitive parts from assemblies in protective packaging or nonconductive foam.
- Use transporters and conveyors made of antistatic belts and roller bushings. Ensure that mechanized equipment used for moving materials is wired to ground and that proper materials are selected to avoid static charging. When grounding is not possible, use an ionizer to dissipate electric charges.

4.6 Workstation Precautions

Use the following grounding precautions at workstations:

- Cover the workstation with approved static-shielding material (refer to [Table 4-2, “Static-Shielding Materials”](#)).
- Use a wrist strap connected to a properly grounded work surface and use properly grounded tools and equipment.
- Use conductive field service tools such as cutters, screwdrivers, and vacuums.
- When fixtures must directly contact dissipative surfaces, use fixtures made only of static-safe materials.
- Keep the work area free of nonconductive materials such as ordinary plastic assembly aids and Styrofoam.
- Handle electrostatic-sensitive components, parts, and assemblies by the case or PCM laminate. Handle these items only at static-free workstations.
- Avoid contact with pins, leads, or circuitry.
- Turn off power and input signals before inserting or removing connectors or test equipment.

4.7 Grounding Equipment and Methods

Grounding equipment must include either a wrist strap or a foot strap at a grounded workstation.

- When seated, wear a wrist strap connected to a grounded system. Wrist straps are flexible straps with a minimum of one megohm $\pm 10\%$ resistance in the ground cords. To provide proper ground, wear a strap snugly against the skin at all times. On grounded mats with banana-plug connectors, use alligator clips to connect a wrist strap.

- When standing, use foot straps and a grounded floor mat. Foot straps (heel, toe, or boot straps) can be used at standing workstations and are compatible with most types of shoes or boots. On conductive floors or dissipative floor mats, use foot straps on both feet with a minimum of one megohm resistance between the operator and ground. To be effective, the conductive strips must be worn in contact with the skin.

Other grounding equipment recommended for use in preventing electrostatic damage includes:

- Antistatic tape
- Antistatic smocks, aprons, and sleeve protectors
- Conductive bins and other assembly or soldering aids
- Nonconductive foam
- Conductive tabletop workstations with ground cords of one megohm resistance
- Static-dissipative tables or floor mats with hard ties to the ground
- Field service kits
- Static awareness labels
- Material-handling packages
- Nonconductive plastic bags, tubes, or boxes
- Metal tote boxes
- Electrostatic voltage levels and protective materials

Table 4-1 shows how humidity affects the electrostatic voltage levels generated by different activities.

Table 4-1
Typical Electrostatic Voltage Levels

Event	Relative Humidity		
	10%	40%	55%
Walking across carpet	35,000 V	15,000 V	7,500 V
Walking across vinyl floor	12,000 V	5,000 V	3,000 V
Motions of bench worker	6,000 V	800 V	400 V
Removing DIPS from plastic tube	2,000 V	700 V	400 V
Removing DIPS from vinyl tray	11,500 V	4,000 V	2,000 V
Removing DIPS from Styrofoam	14,500 V	5,000 V	3,500 V
Removing bubble pack from PCB	26,500 V	20,000 V	7,000 V
Packing PCBs in foam-lined box	21,000 V	11,000 V	5,000 V



A product can be degraded by as little as 700 V.

Table 4-2 lists the shielding protection provided by antistatic bags and floor mats.

Table 4-2
Static-Shielding Materials

Material	Use	Voltage Protection Level
Antistatic plastic	Bags	1,500 V
Carbon-loaded plastic	Floor mats	7,500 V
Metallized laminate	Floor mats	5,000 V

5

Removal and Replacement Procedures

This chapter provides removal and replacement procedures.

There are as many 113 screws, in 9 different sizes and types, that may have to be removed, replaced, or loosened when servicing the computer. Make special note of each screw size and location during removal and replacement.

Refer to [Appendix C, “Screw Listing,”](#) for detailed information on screw and nut sizes, locations, and usage.

5.1 Serial Number

Report the computer serial number to HP when requesting information or ordering spare parts. The serial number is located on the bottom of the computer.

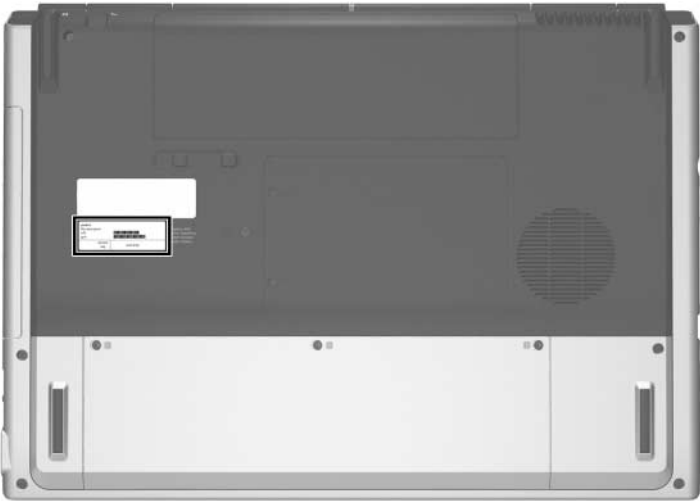

Serial Number Location

5.2 Disassembly Sequence Chart

Use the chart below to determine the section number to be referenced when removing computer components.

Disassembly Sequence Chart

Section	Description	# of Screws Removed
6.3	Preparing the Computer for Disassembly	
	Battery pack	0
6.4	Hard Drive	3 loosened to remove the hard drive cover 2 to remove each hard drive 4 to disassemble each hard drive
6.5	Computer Feet	0
6.6	Memory Module	2 loosened to remove the memory/Mini PCI module compartment cover 2 loosened to release the memory shield
6.7	Mini PCI Communications Module	0
	 To prevent an unresponsive system and the display of a warning message, install only a Mini PCI device authorized for use in your computer by the governmental agency that regulates wireless devices in your country. If you install a device and then receive a warning message, remove the device to restore computer functionality. Then contact Customer Care.	
6.8	RTC Battery	0
6.9	Optical Drive	1
6.10	Switch Cover	5

Disassembly Sequence Chart (*Continued*)

Section	Description	# of Screws Removed
6.11	Keyboard Assembly Frame	2
6.12	LED Board	4
6.13	Keyboard	5
6.14	Display Assembly	6 to remove the display assembly 6 to remove the display bezel 4 to remove the display panel 4 to remove each display hinge 1 to remove the display inverter
6.15	Top Cover	25
6.16	System Board	8
6.17	Bluetooth Module	2
6.18	Modem Connector Cable	0
6.19	USB Board	0
6.20	Speakers	2
6.21	Heat Sink	4
6.22	Processor	0
6.23	Fan Assembly	5
6.24	PC Card Assembly	2

5.3 Preparing the Computer for Disassembly

Before you begin any removal or installation procedures:

1. Shut down the computer. If you are unsure whether the computer is off or in hibernation, turn the computer on, and then shut it down through the operating system.
2. Disconnect all external devices connected to the computer.
3. Disconnect the power cord.

Battery Pack Spare Part Number Information

8-cell, 4.4-hour battery pack

403808-001

4. Remove the battery pack by following these steps:
 - a. Turn the computer upside down with the front toward you.
 - b. Slide the battery pack release latch **1** to the left. (The battery pack disengages from the computer.)
 - c. Lift the front edge of the battery pack **2** up and swing it back to remove it.



Removing the Battery Pack

Reverse the above procedure to install the battery pack.

5.4 Hard Drive

Hard Drive Spare Part Number Information

7200 rpm, 100-GB	405938-001
5400 rpm, 80-GB	403803-001
4200-rpm, 120-GB	405939-001
4200-rpm, 100-GB	403804-001
4200-rpm, 60-GB	405937-001



All hard drive spare part kits include a hard drive frame and hard drive connector.

1. Prepare the computer for disassembly (refer to [Section 5.3](#)).

2. Loosen the three black Phillips PM2.5×6.0 screws ❶ that secure the hard drive cover to the computer.
3. Lift the rear edge of the hard drive cover ❷ and swing it up and forward and remove it.



The hard drive cover is included in the Plastics Kit, spare part number 403812-001.

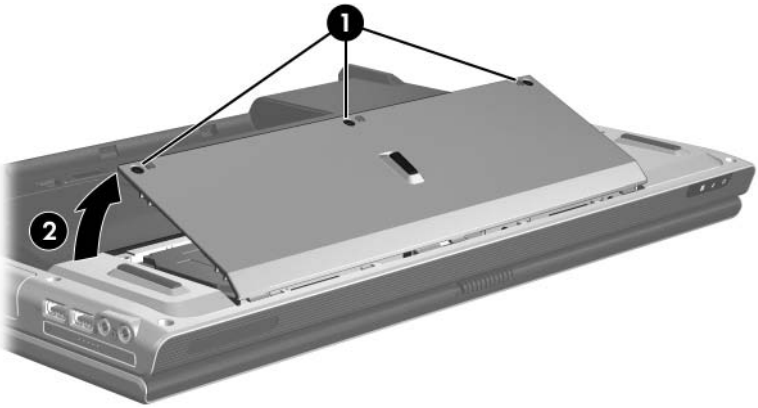

Removing the Hard Drive Cover

4. Remove the two silver Phillips PM2.5×6.0 hard drive retention screws **1** that secure each hard drive to the computer.
5. Slide the hard drive **2** away from the hard drive connector.
6. Remove the hard drive from the hard drive bay **3**.

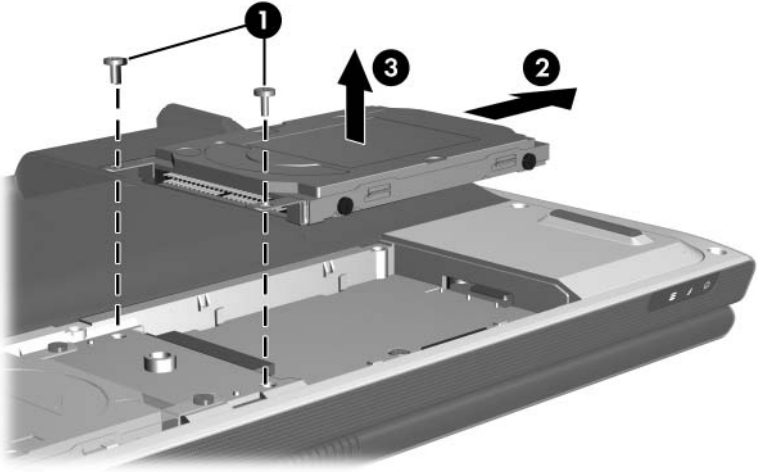

Removing the Hard Drive

7. Remove the four Phillips PM3.0×4.0 hard drive frame screws ❶ that secure the hard drive frame to the hard drive.
8. Lift the hard drive straight up ❷ to remove it from the hard drive frame.

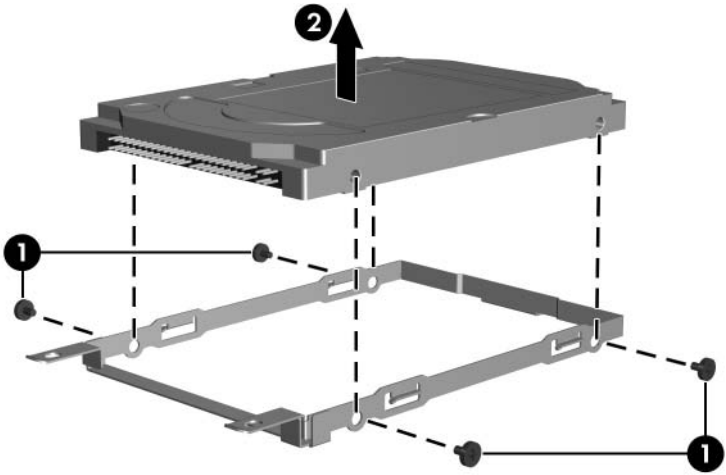

Removing the Hard Drive Frame

Reverse the above procedure to reassemble and install the hard drive.

5.5 Computer Feet

The computer feet are adhesive-backed rubber pads. The feet are included in the Plastics Kit, spare part number 403812-001.



Replacing the Computer Feet

5.6 Memory Module

Memory Module Spare Part Number Information

1024 MB	403800-001
512 MB	403799-001
256 MB	403573-001

1. Prepare the computer for disassembly (refer to [Section 5.3](#)).
2. Position the computer with the rear panel toward you.

3. Loosen the two black Phillips PM2.5×6.0 screws ❶ that secure the memory/Mini PCI module compartment cover to the computer.
4. Lift the right side of the cover ❷ and swing it up and to the left and remove it.



The memory/Mini PCI module compartment cover is included in the Plastics Kit, spare part number 403812-001.

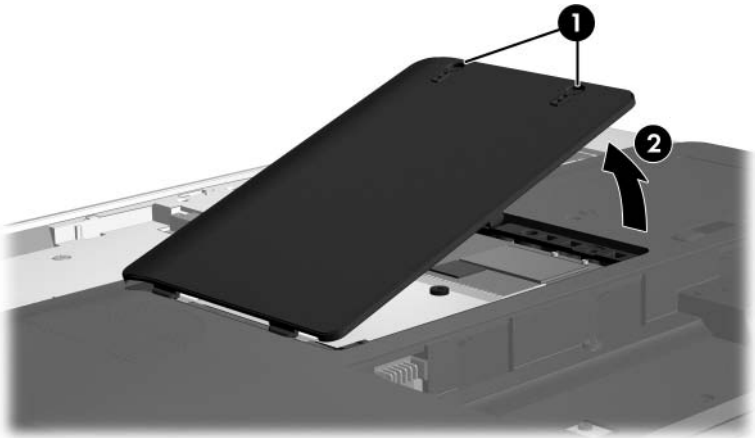

Removing the Memory/Mini PCI Module Compartment Cover

5. Loosen the two Phillips PM2.5×4.0 screws **1** that secure the memory shield to the computer.
6. Lift the right side of the memory shield **2** and swing it to the left as far as it will go.

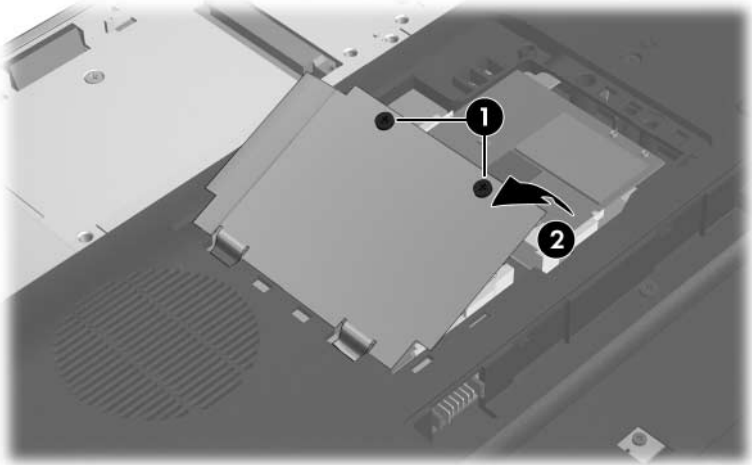

Releasing the Memory Shield

7. Spread the retaining tabs **1** on each side of the memory module socket to release the memory module. (The edge of the module opposite the socket rises away from the computer.)
8. Slide the module away from the socket at an angle **2**.
9. Remove the memory module.



Memory modules are designed with notches **3** to prevent incorrect installation into the memory module socket.

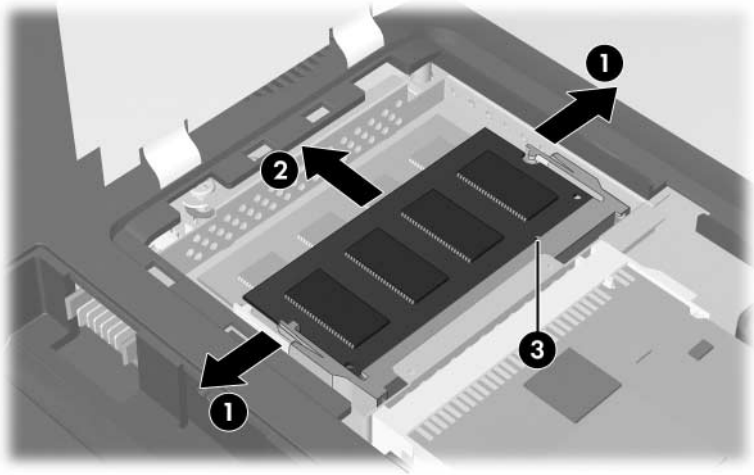

Removing the Memory Module

Reverse the above procedure to install a memory module.

5.7 Mini PCI Communications Module

Mini PCI Communications Module Spare Part Number Information

802.11a/b/g wireless local access network (WLAN) module for use in North America	403791-001
802.11a/b/g WLAN module for use in the rest of the world	403792-001
802.11b/g WLAN module for use in North America	392557-001
802.11b/g WLAN module for use in the rest of the world	392557-002

1. Prepare the computer for disassembly ([Section 5.3](#)).
2. Remove the memory/Mini PCI module compartment cover ([Section 5.6](#)).



Before disconnecting the antenna cables, make note of which cable is attached to which antenna clip on the Mini PCI communications module.

3. Disconnect the auxiliary and main antenna cables **1** from the Mini PCI communications module.
4. Spread the two retaining tabs **2** on each side of the Mini PCI socket to release the Mini PCI communications module. (The edge of the module opposite the socket rises away from the computer.)
5. Remove the Mini PCI communications module by pulling the card away from the socket at a 45-degree angle **3**.



The Mini PCI communications module is designed with a notch **4** to prevent incorrect installation.

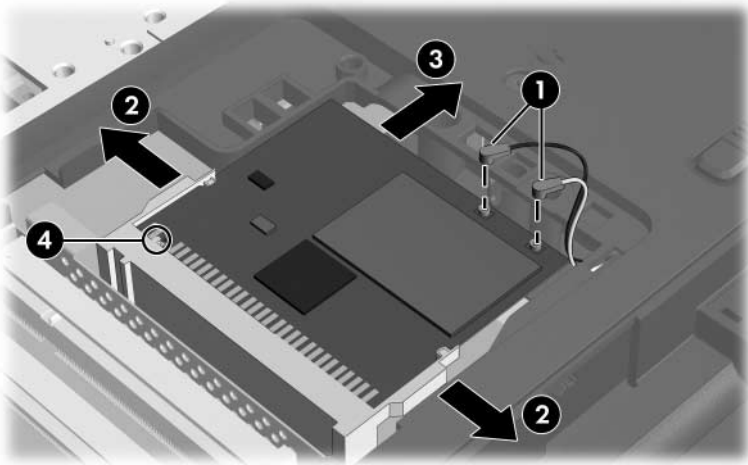

Removing a Mini PCI Communications Module

Reverse the above procedure to install a Mini PCI communications module.

5.8 RTC Battery

RTC Battery Spare Part Number Information

RTC battery	403819-001
-------------	------------

1. Prepare the computer for disassembly ([Section 5.3](#)).
2. Remove the memory/Mini PCI module compartment cover ([Section 5.6](#)).
3. Remove the Mini PCI communications module ([Section 5.7](#)).

4. Remove the RTC battery from the socket on the system board.

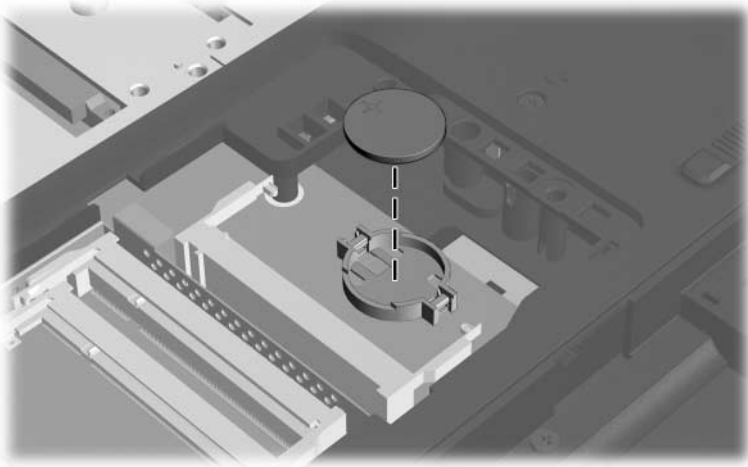

Removing the RTC Battery

Reverse the above procedure to install an RTC battery.

5.9 Optical Drive

Optical Drive Spare Part Number Information

DVD±RW and CD-RW Double Layer Combo Drive with LightScribe	403807-001
DVD±RW and CD-RW Double Layer Combo Drive	403806-001
DVD/CD-RW Combo Drive	403805-001

1. Prepare the computer for disassembly ([Section 5.3](#)).
2. Position the computer with the left side toward you.

3. Remove the Phillips PM2.5×13.0 screw ❶ that secures the optical drive to the computer.
4. Insert a thin tool, such as an unbent paper clip ❷, into the media tray release hole and release the media tray.
5. Use the media tray to slide the optical drive out of the computer ❸.
6. Remove the optical drive.

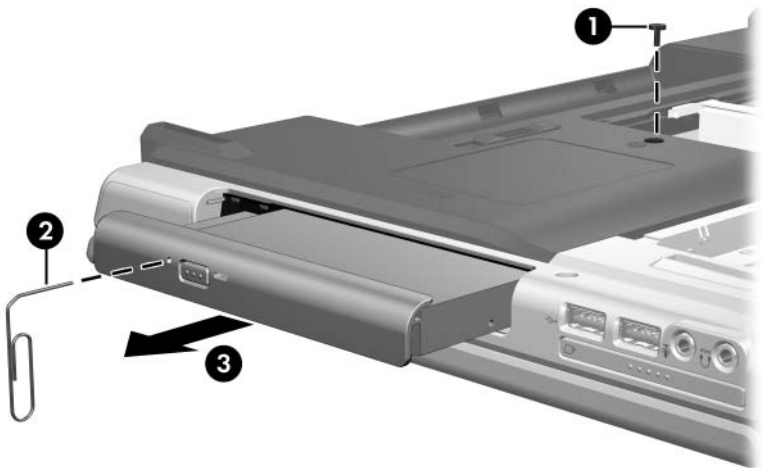

Removing the Optical Drive

Reverse the above procedure to install an optical drive.

5.10 Switch Cover

Switch Cover Spare Part Number Information

Switch cover (includes LED board and LED board cable)	403817-001
---	------------

1. Prepare the computer for disassembly ([Section 5.3](#)).
2. Remove the two Phillips PM2.5×13.0 screws **1** and the three Phillips PM2.5×4.0 screws **2** that secure the switch cover to the computer.

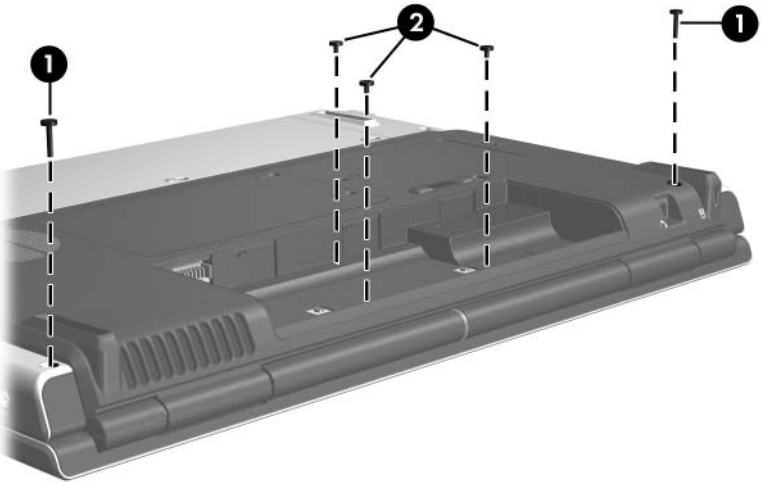

Removing the Switch Cover Screws

3. Turn the computer display-side up with the front toward you.
4. Open the computer as far as possible.
5. Insert a flat-bladed screwdriver under the display hinge cover sections ❶ of the switch cover.
6. Lift the switch cover until the left and right sides ❷ of the switch cover disengage from the computer.
7. Remove the switch cover.

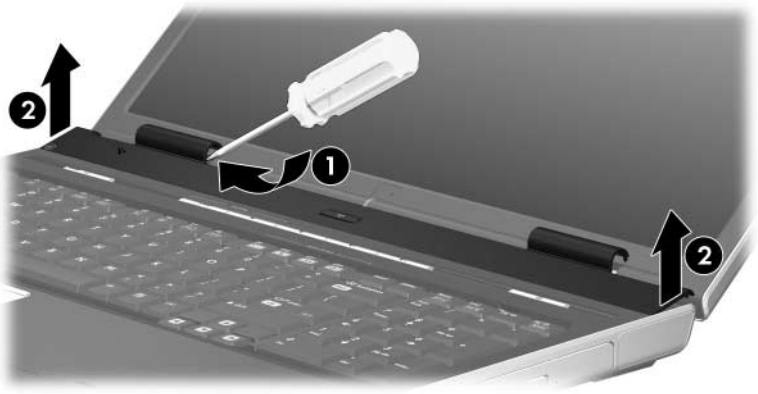

Removing the Switch Cover

Reverse the above procedure to install the switch cover.

5.11 Keyboard Assembly Frame

Keyboard Assembly Frame Spare Part Number Information

Keyboard assembly frame

403818-001

1. Prepare the computer for disassembly ([Section 5.3](#)).
2. Remove the memory/Mini PCI module compartment cover ([Section 5.6](#)).
3. Remove the switch cover ([Section 5.10](#)).
4. Turn the computer upside down with the front toward you.
5. Remove the Phillips PM2.5×13.0 screw ❶ in the memory/Mini PCI module compartment that secures the keyboard assembly frame to the computer.
6. Remove the silver Phillips PM2.5×6.0 screw ❷ in the battery bay that secures the keyboard assembly frame to the computer.

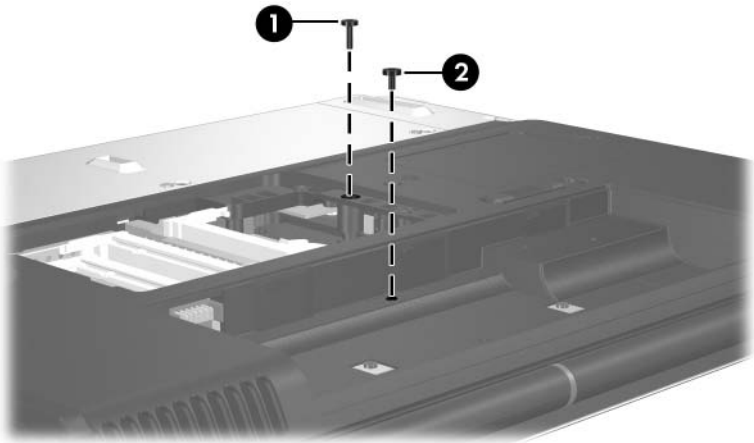

Removing the Keyboard Assembly Frame Screws

7. Turn the computer display-side up with the front toward you.
8. Open the computer as far as possible.
9. Lift and hold the rear edge of the keyboard until the LED board cable connector is accessible.



Releasing the Keyboard Assembly Frame

10. Release the zero insertion force (ZIF) connector **1** to which the LED board cable is connected and disconnect the cable **2**.

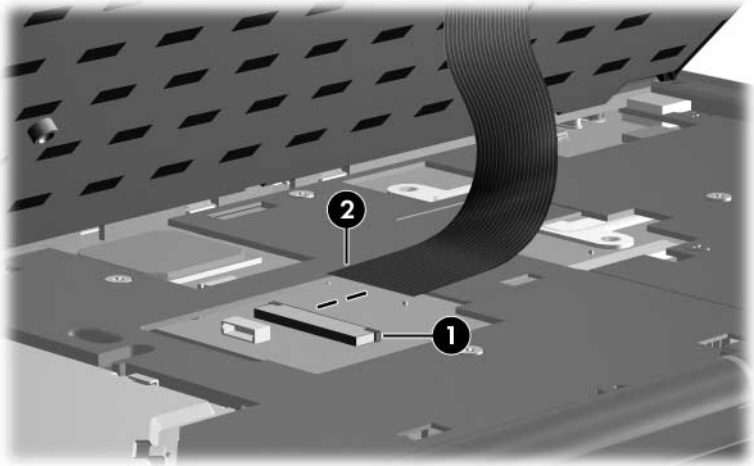

Releasing the Keyboard Assembly Frame

11. Swing the keyboard assembly frame **1** forward until the assembly rests on the palm rest.
12. Release the ZIF connector to which the keyboard cable **2** is attached and disconnect the keyboard cable **3**.
13. Remove the keyboard assembly frame.



Removing the Keyboard Assembly Frame

Reverse the above procedure to install the keyboard assembly frame.

5.12 LED Board

LED Board Spare Part Number Information

LED board (includes LED board cable)

403833-001

1. Prepare the computer for disassembly ([Section 5.3](#)) and then remove the following components:
 - a. Memory/Mini PCI module compartment cover ([Section 5.6](#))
 - b. Switch cover ([Section 5.10](#))
 - c. Keyboard assembly frame ([Section 5.11](#))
2. Turn the keyboard assembly frame upside down with the LED board toward you.

3. Remove the four Phillips PM2.5×4.0 screws ❶ that secure the LED board to the keyboard frame.
4. Remove the LED board ❷.

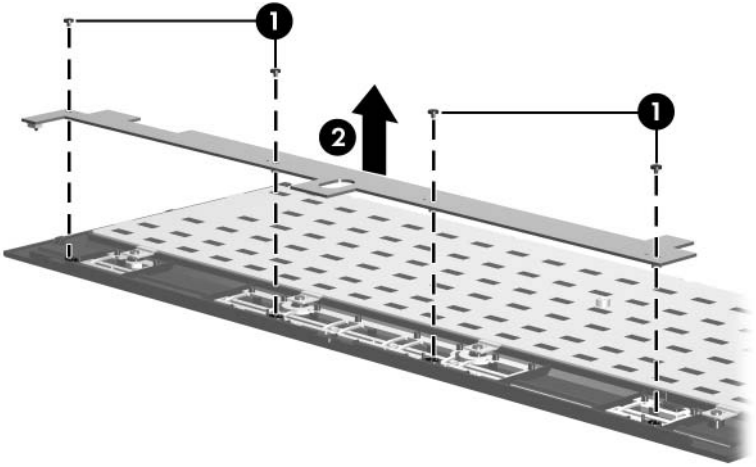

Removing the LED Board

Reverse the above procedure to install the LED board.

5.13 Keyboard

Keyboard Spare Part Number Information

For use in:

France	403809-051	Spain	403809-071
French Canada	403809-121	Sweden and Finland	403809-101
Germany	403809-041	United Kingdom	403809-031
Italy	403809-061	United States	403809-001
Norway	403809-091		

1. Prepare the computer for disassembly ([Section 5.3](#)) and then remove the following components:
 - a. Memory/Mini PCI module compartment cover ([Section 5.6](#))
 - b. Switch cover ([Section 5.10](#))
 - c. Keyboard assembly frame ([Section 5.11](#))
2. Turn the keyboard assembly frame upside down with the LED board toward you.

3. Remove the five Phillips PM2.5×4.0 screws ❶ that secure the keyboard to the keyboard frame.
4. Remove the keyboard ❷.

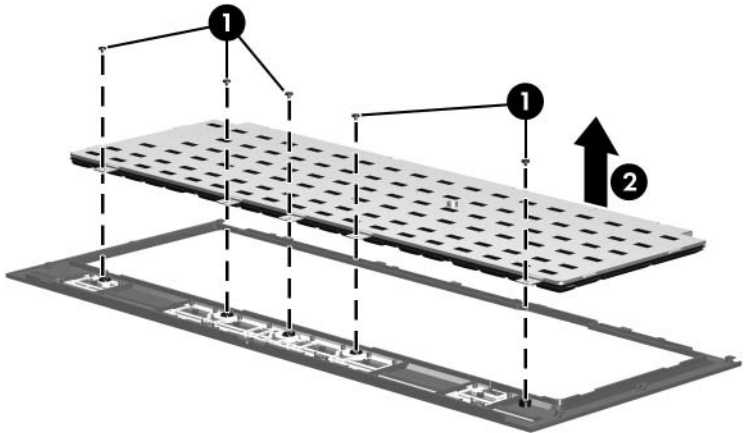

Removing the Keyboard

Reverse the above procedure to install the keyboard.

5.14 Display Assembly

Display Assembly Spare Part Number Information

17-inch, WSXGA+ with BrightView	403797-001
17-inch, WXGA+ with BrightView	403796-001

1. Prepare the computer for disassembly ([Section 5.3](#)).
2. Remove the memory/Mini PCI module compartment cover ([Section 5.6](#)).



Before disconnecting the antenna cables, make note of which cable is attached to which antenna clip on the Mini PCI communications module.

3. Disconnect the auxiliary and main antenna cables from the Mini PCI communications module.

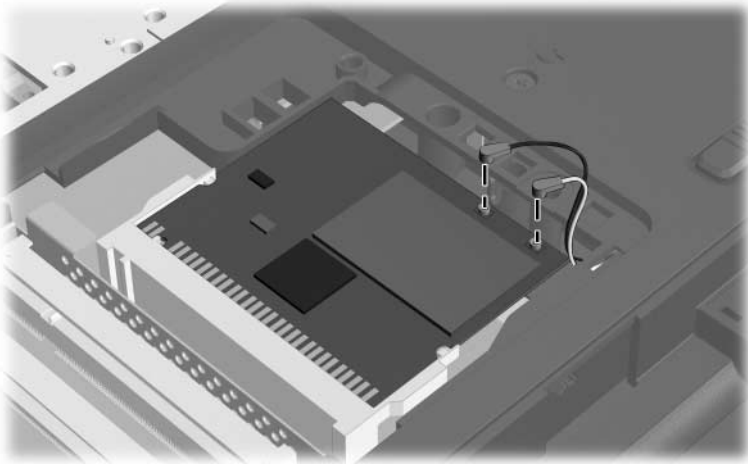

Disconnecting the Wireless Antenna Cables

4. Remove the switch cover ([Section 5.10](#)).
5. Remove the keyboard assembly frame ([Section 5.11](#)).
6. Disconnect the display cable ❶ from the system board.
7. Remove the wireless antenna cables from the clips ❷ in the top cover.

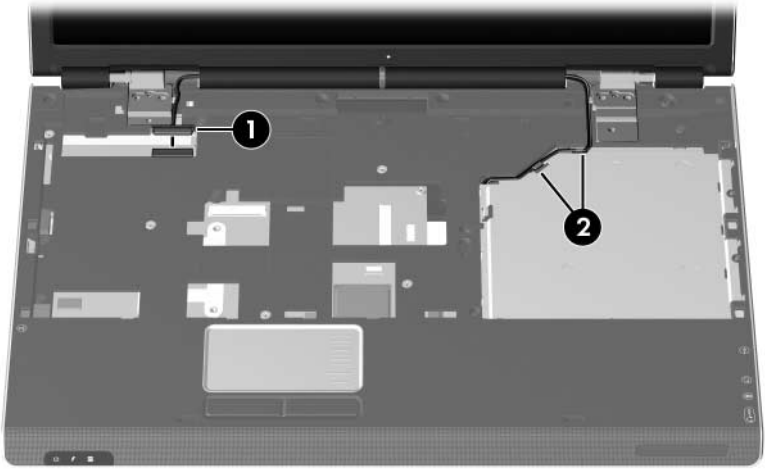

Disconnecting the Display and Wireless Antenna Cables



CAUTION: Support the display assembly when removing the following screws. Failure to support the display assembly can result in damage to the display assembly and other computer components.

8. Remove the the silver Phillips PM2.5×6.0 screw ❶ and the five Phillips PM2.5×9.0 screws ❷ that secure the display assembly to the computer.
9. Lift the display assembly straight up and remove it ❸.

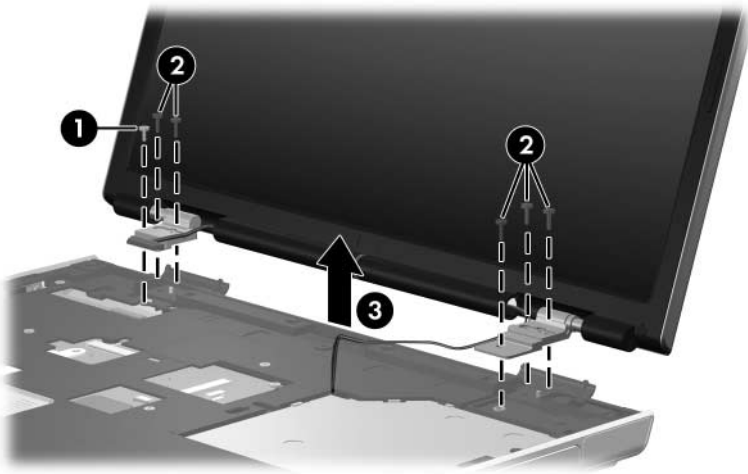

Removing the Display Assembly

Display Assembly Subcomponents

Spare Part Number Information

Display Plastics Kit, includes: 403881-001

- Display bezel
- Display enclosure
- Display release latch actuator and hooks (not illustrated)

Display Screw Kit, includes: 403886-001

- Phillips PM2.5×7.0 screws
 - Phillips PM2.5×5.0 screws
 - Rubber screw covers
-

10. Remove the six rubber screw covers **1** and **2** and the six Phillips PM2.5×7.0 screws **3** that secure the display bezel to the display assembly.



The four rubber screw covers **1** on the top edge of the display bezel are larger than the two rubber screw covers **2** on the bottom edge of the bezel.

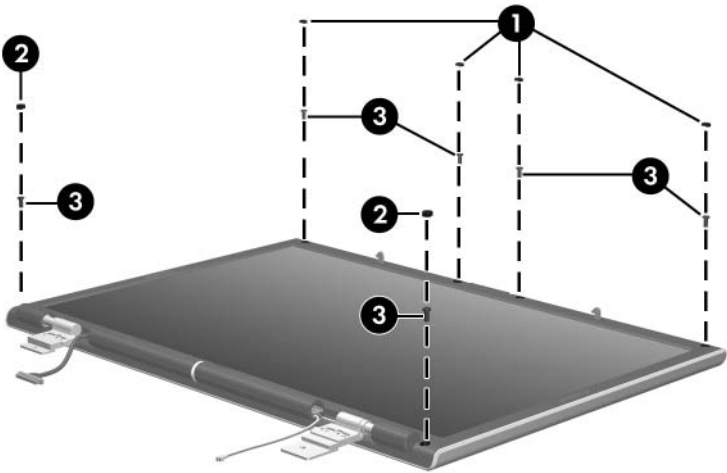

Removing the Display Bezel Screws

11. Flex the inside edges of the left and right sides ❶ and the top and bottom sides ❷ of the display bezel until the bezel disengages from the display assembly.
12. Remove the display bezel ❸.

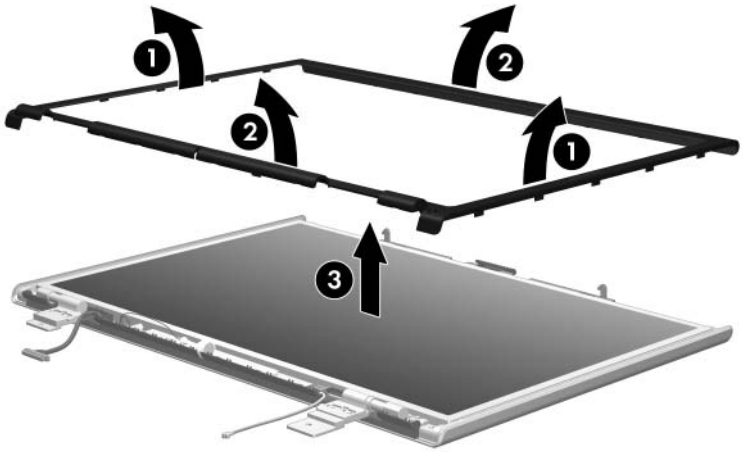

Removing the Display Bezel

13. Disconnect the following cables:

- ❶ Display panel cable
- ❷ Light sensor cable
- ❸ Display inverter cable

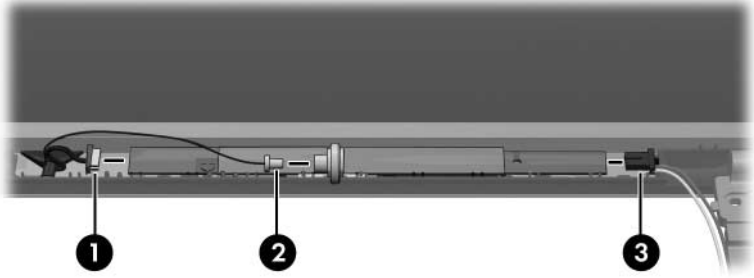

Disconnecting the Display Panel Cables

Display Assembly Subcomponents

Spare Part Number Information

Display Panel Kit (includes display panel cable)

403885-001

14. Remove the two Phillips PM2.5×4.0 screws ❶ and the two Phillips PM2.5×7.0 screws ❷ that secure the display panel to the display enclosure.
15. Remove the display panel ❸.

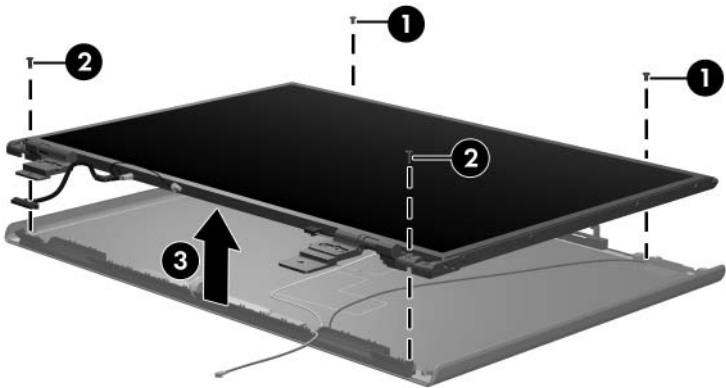

Removing the Display Panel

Display Assembly Subcomponents

Spare Part Number Information

Display Hinge Kit

403884-001

16. Remove the four Phillips PM2.0×4.0 screws ❶ that secure each display hinge to the display panel.
17. Remove the display hinges ❷.

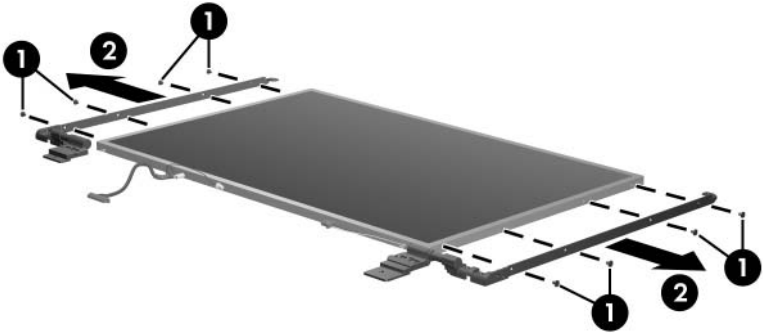

Removing the Display Hinges

Display Assembly Subcomponents

Spare Part Number Information

Display inverter board

403831-001

18. Remove the Phillips PM2.0×4.0 screw **1** that secures the display inverter board to the display enclosure.
19. Swing the top edge of the board **2** up and forward and remove it.

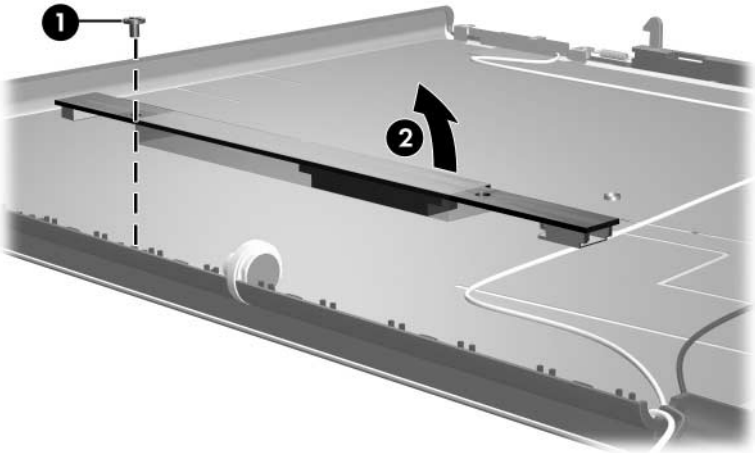

Removing the Display Inverter Board

Display Assembly Subcomponents

Spare Part Number Information

Display Plastics Kit, includes:	403881-001
■ Display enclosure	
■ Display bezel	
■ Display release latch actuator and hooks (not illustrated)	
Wireless Antenna Kit (includes cable and transceivers)	403882-001

20. Release the retention tabs **1** built in to the display enclosure lining that secure the wireless antenna cables to the display enclosure.
21. Detach the wireless antenna transceivers **2** from the display enclosure.
22. Remove the wireless antenna transceivers and cables **1**.

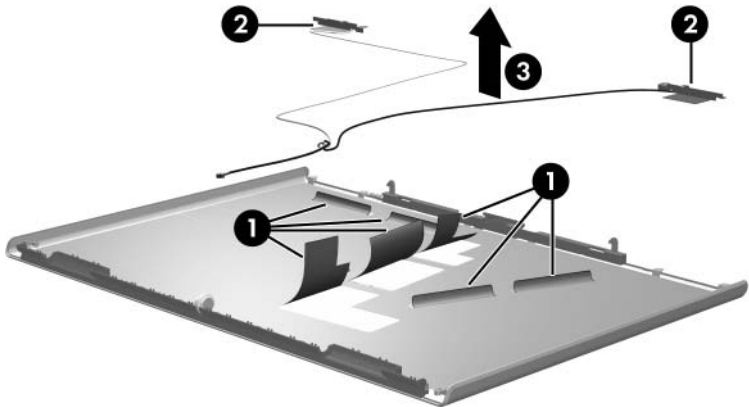

Removing the Wireless Antenna Transceivers and Cables

Reverse the above procedure to reassemble and install the display assembly.

5.15 Top Cover

Top Cover Spare Part Number Information

Top cover (includes TouchPad)	403822-001
-------------------------------	------------

1. Prepare the computer for disassembly ([Section 5.3](#)) and then remove the following components:
 - a. Hard drive ([Section 5.4](#))
 - b. Memory/Mini PCI module compartment cover ([Section 5.6](#))
 - c. Optical drive ([Section 5.9](#))
 - d. Switch cover ([Section 5.10](#))
 - e. Keyboard assembly frame ([Section 5.11](#))
 - f. Display assembly ([Section 5.14](#))

2. Release the ZIF connector to which the TouchPad cable ❶ is connected and disconnect the TouchPad cable ❷ from the system board.



The TouchPad cable is included in the Cable Kit, spare part number 403814-001.

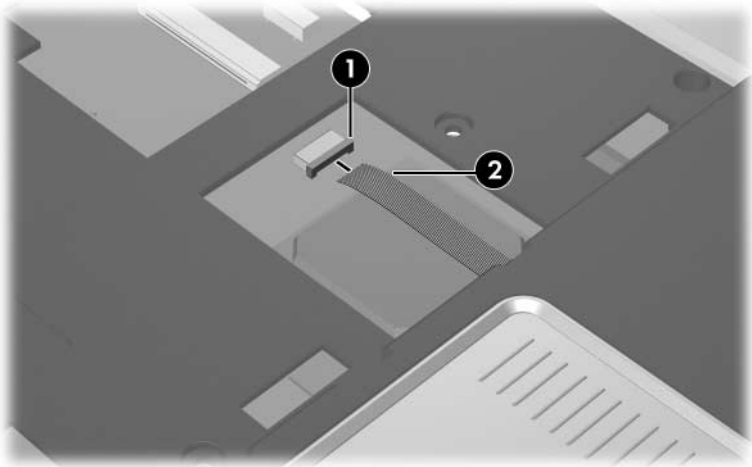

Disconnecting the TouchPad Cable

3. Turn the computer upside down with the front toward you.

4. Remove the two Phillips PM2.5×4.0 screws **1** and three silver Phillips PM2.5×6.0 screws **2** that secure the top cover to the computer.

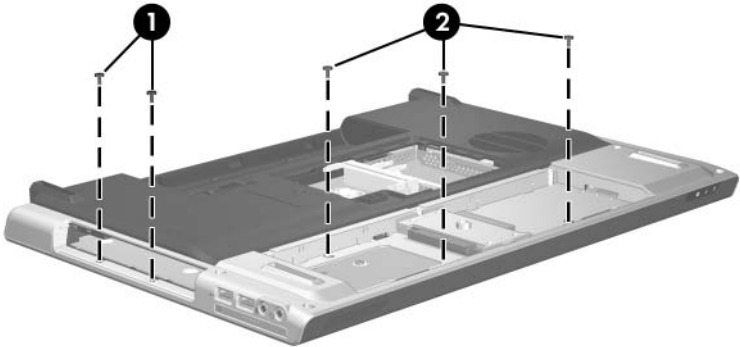

Removing the Top Cover Screws, Part 1

5. Remove the five Phillips PM2.5×13.0 screws that secure the top cover to the computer.

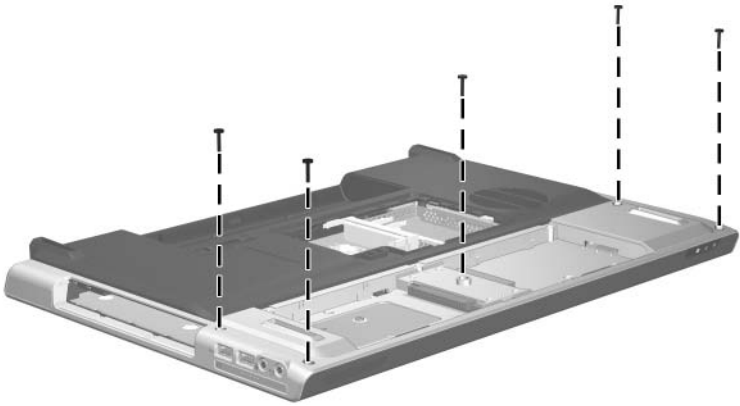

Removing the Top Cover Screws, Part 2

6. Turn the computer right-side up with the front toward you.
7. Remove the nine silver Phillips PM2.5×6.0 screws that secure the top cover to the computer.

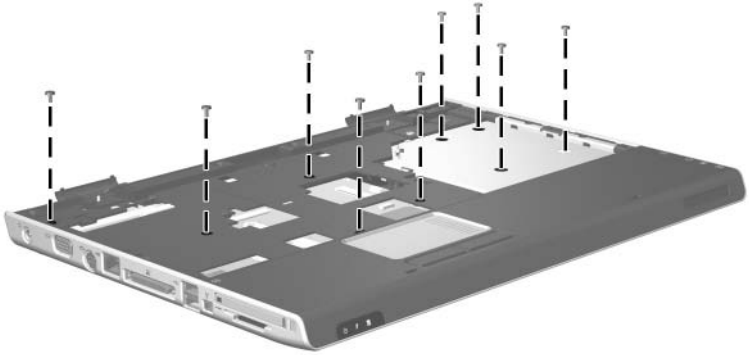

Removing the Top Cover Screws, Part 3

8. Remove the six Phillips PM2.5×13.0 screws that secure the top cover to the computer.

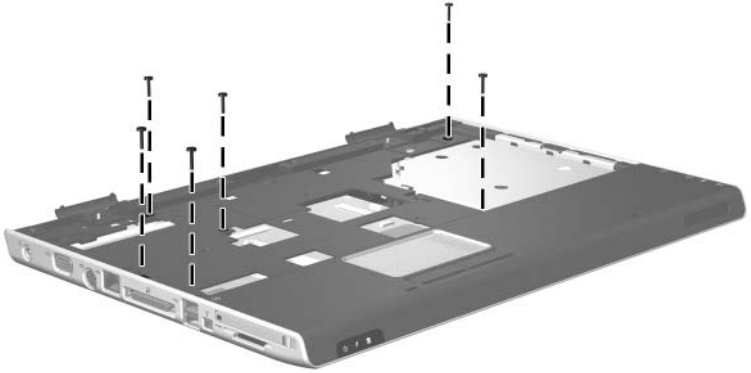

Removing the Top Cover Screws, Part 4

9. Lift up the rear edge of the top cover ❶ until it disengages from the base enclosure.
10. Lift the top cover ❷ straight up and remove it.

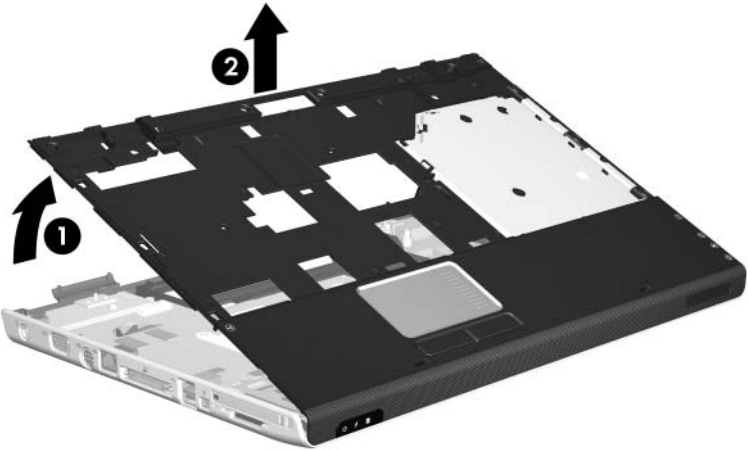

Removing the Top Cover

Reverse the above procedure to install the top cover.

5.16 System Board

System Board Spare Part Number Information

System board

403790-001



When replacing the system board, ensure that the following components are removed from the defective system board and installed on the replacement system board:

- Memory modules ([Section 5.6](#))
 - Mini PCI communications module ([Section 5.7](#))
 - RTC battery ([Section 5.8](#))
 - Speaker ([Section 5.20](#))
 - Heat sink ([Section 5.21](#))
 - Processor ([Section 5.22](#))
 - Fan assembly ([Section 5.23](#))
 - PC Card assembly ([Section 5.24](#))
-

1. Prepare the computer for disassembly ([Section 5.3](#)), and then remove the following components:
 - a. Hard drive ([Section 5.4](#))
 - b. Memory/Mini PCI module compartment cover ([Section 5.6](#))
 - c. Optical drive ([Section 5.9](#))
 - d. Switch cover ([Section 5.10](#))
 - e. Keyboard assembly frame ([Section 5.11](#))
 - f. Display assembly ([Section 5.14](#))
 - g. Top cover ([Section 5.15](#))

2. Press in on the ExpressCard slot bezel ❶ to release it.
3. Remove the ExpressCard slot bezel ❷.

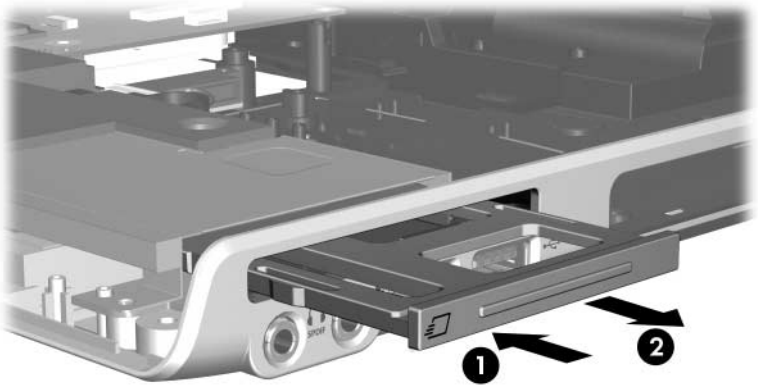

Removing the ExpressCard Slot Bezel

4. Remove the two silver Phillips PM2.5×6.0 screws **1** that secure the display hinge support bracket to the computer.
5. Remove the display hinge support bracket **2**.

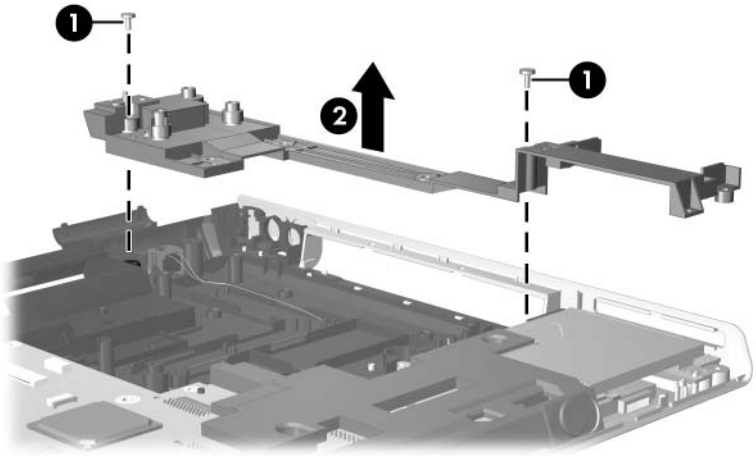

Removing the Display Hinge Support Bracket

6. Remove the following screws:

- ❶ One Phillips PM2.5×9.0 screw that secures the system board to the base enclosure
- ❷ Four silver Phillips PM2.5×6.0 screws that secure the system board to the base enclosure
- ❸ One Phillips PM2.5×4.0 screw that secures the connector board to the base enclosure

7. Remove the ExpressCard assembly ❹.

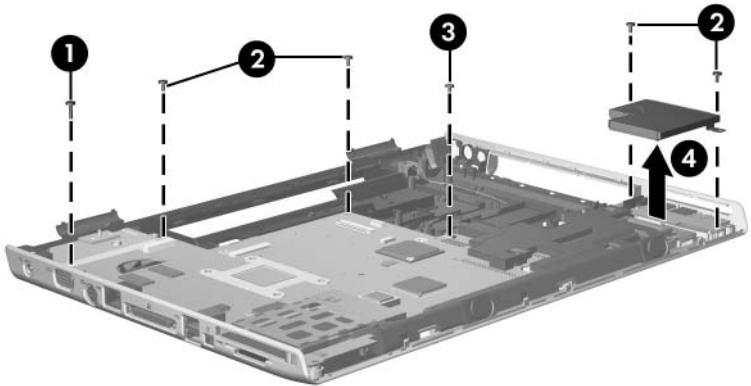

Removing the System Board Screws

8. Disconnect the following cables from the system board:

- ❶ Modem cable
- ❷ Bluetooth module cable
- ❸ USB board cable

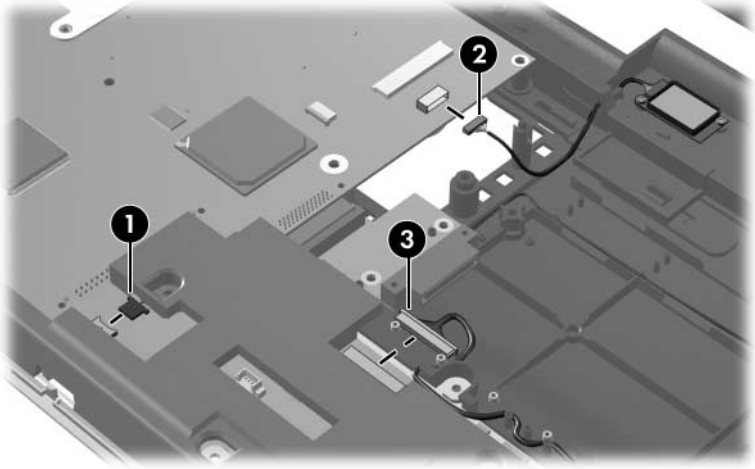

Disconnecting the Modem, Bluetooth Module, and USB Board Cables

9. Lift the right side of the system board **1** until the right side of the board is clear of the base enclosure.
10. Make sure the PC Card eject button **2** is depressed and clears the base enclosure.
11. Slide the system board **3** to the right at an angle and remove it.

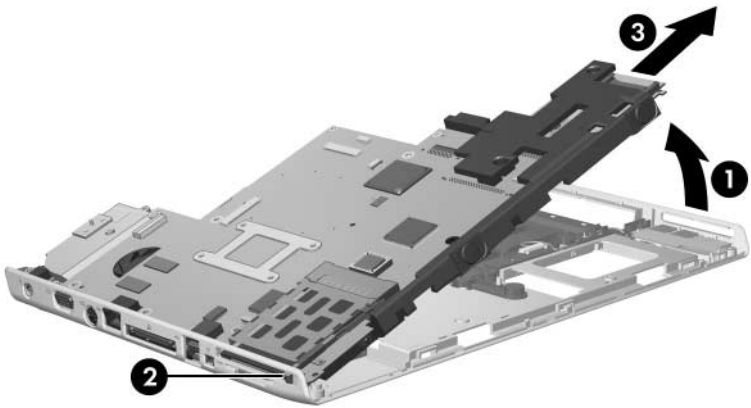

Removing the System Board

12. Remove the optical drive connector board from the system board.



The optical drive connector board is available using spare part number 403829-001.

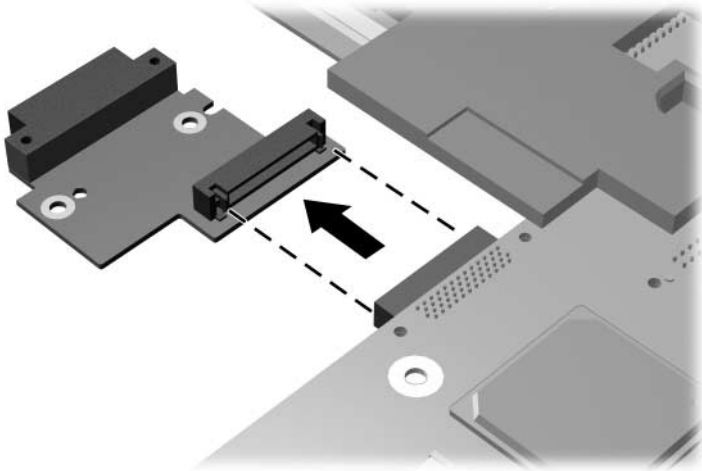

Removing the Optical Drive Connector Board

Reverse the above procedures to install the system board.

5.17 Bluetooth Module

Bluetooth Module Spare Part Number Information

Bluetooth module (includes Bluetooth module cable)

1. Prepare the computer for disassembly ([Section 5.3](#)), and then remove the following components:
 - a. Hard drive ([Section 5.4](#))
 - b. Memory/Mini PCI module compartment cover ([Section 5.6](#))
 - c. Optical drive ([Section 5.9](#))
 - d. Switch cover ([Section 5.10](#))
 - e. Keyboard assembly frame ([Section 5.11](#))
 - f. Display assembly ([Section 5.14](#))
 - g. Top cover ([Section 5.15](#))

2. Remove the two Phillips PM2.0x4.0 screws **1** that secure the Bluetooth module to the base enclosure
3. Remove the Bluetooth module from the base enclosure **2**.
4. Disconnect the Bluetooth module cable **3** from the Bluetooth module.

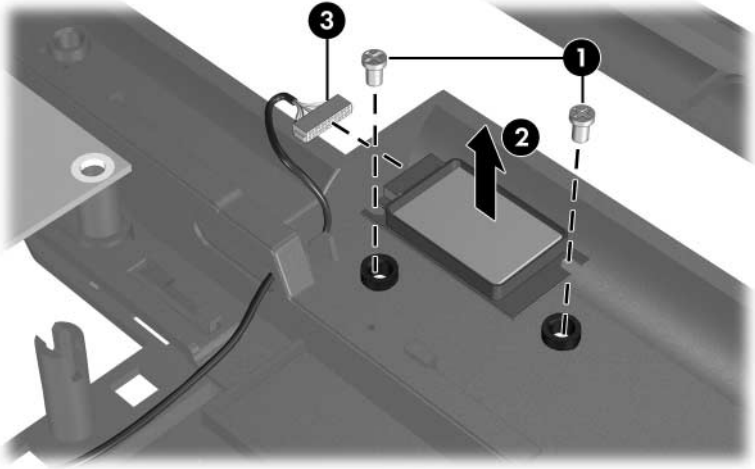

Removing the Bluetooth Module

5. Slide and hold the battery release latch acuator **1** to the right.
6. Slide the Bluetooth module cable **2** through the hole in the battery release latch actuator **3** and the clips in the base enclosure.
7. Remove the Bluetooth module cable **4** from the clip in the base enclosure.



The Bluetooth module cable is included with the Bluetooth module and is also available in the Cable Kit, spare part number 403814-001.

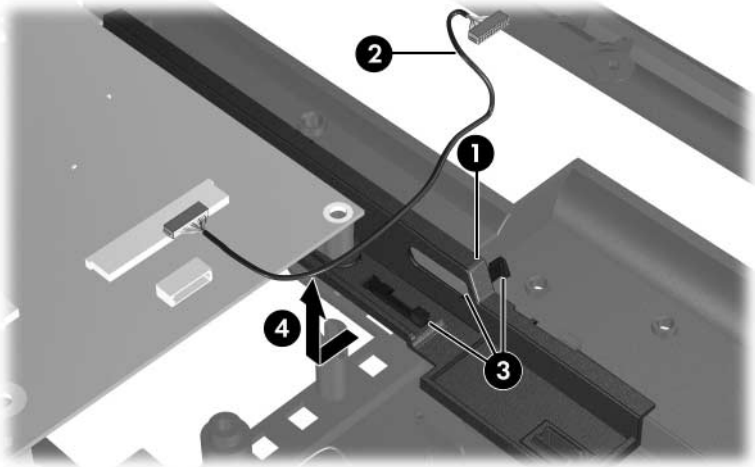

Removing the Bluetooth Module Cable

Reverse the above procedure to install the Bluetooth module.

5.18 Modem Connector Cable



The modem connector cable is included in the Cable Kit, spare part number 403814-001.

1. Prepare the computer for disassembly ([Section 5.3](#)), and then remove the following components:
 - a. Hard drive ([Section 5.4](#))
 - b. Memory/Mini PCI module compartment cover ([Section 5.6](#))
 - c. Optical drive ([Section 5.9](#))
 - d. Switch cover ([Section 5.10](#))
 - e. Keyboard assembly frame ([Section 5.11](#))
 - f. Display assembly ([Section 5.14](#))
 - g. Top cover ([Section 5.15](#))

2. Remove the modem connector **1** from the clip **2** in the base enclosure.
3. Remove the modem connector cable from the routing channel **3** in the base enclosure.

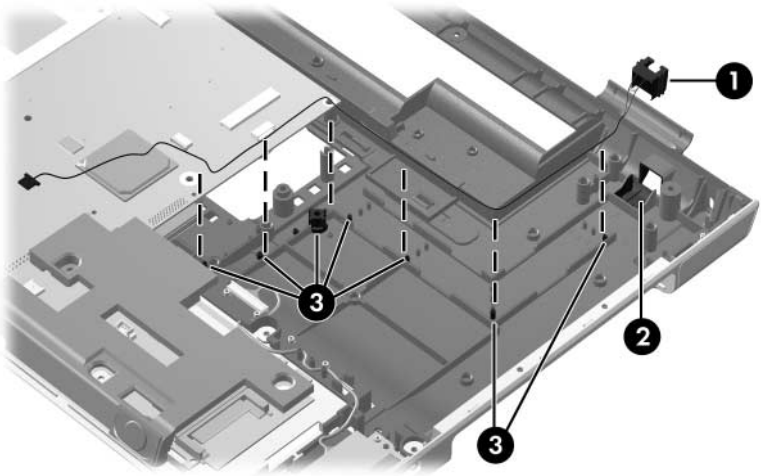

Removing the Modem Connector Cable

Reverse the above procedure to install the modem connector cable.

5.19 USB Board

USB Board Spare Part Number Information

USB board (includes USB board and USB board cable)	403830-001
--	------------

1. Prepare the computer for disassembly ([Section 5.3](#)), and then remove the following components:
 - a. Hard drive ([Section 5.4](#))
 - b. Memory/Mini PCI module compartment cover ([Section 5.6](#))
 - c. Optical drive ([Section 5.9](#))
 - d. Switch cover ([Section 5.10](#))
 - e. Keyboard assembly frame ([Section 5.11](#))
 - f. Display assembly ([Section 5.14](#))
 - g. Top cover ([Section 5.15](#))
 - h. System board ([Section 5.16](#))

2. Remove the USB cable from the routing clips **1** in the base enclosure.
3. Remove the USB board **2** from the base enclosure.
4. Disconnect the USB board cable **3** from the USB board.



The USB board cable is included with the USB board and is also available in the Cable Kit, spare part number 403814-001.

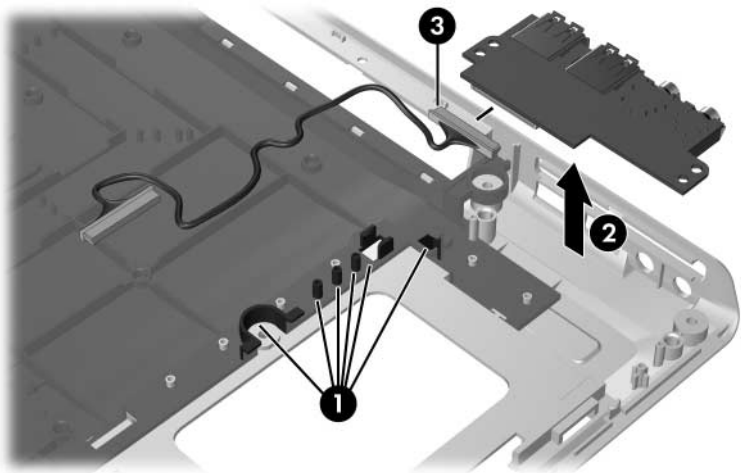

Removing the USB Board

Reverse the above procedure to install a USB board.

5.20 Speakers

Speaker Spare Part Number Information

Speakers

403825-001

1. Prepare the computer for disassembly ([Section 5.3](#)), and then remove the following components:
 - a. Hard drive ([Section 5.4](#))
 - b. Memory/Mini PCI module compartment cover ([Section 5.6](#))
 - c. Optical drive ([Section 5.9](#))
 - d. Switch cover ([Section 5.10](#))
 - e. Keyboard assembly frame ([Section 5.11](#))
 - f. Display assembly ([Section 5.14](#))
 - g. Top cover ([Section 5.15](#))
 - h. System board ([Section 5.16](#))

2. Disconnect the speaker cable from the system board.

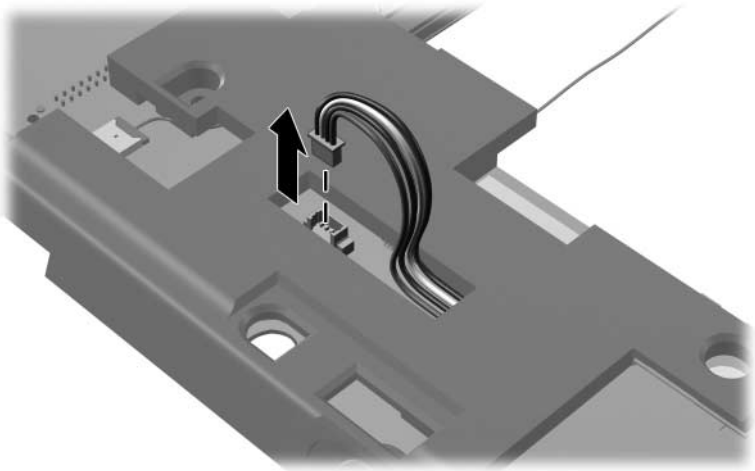

Disconnecting the Speaker Cable

3. Turn the system board upside down with the front toward you.

4. Remove the two silver Phillips PM2.5×6.0 screws ❶ that secure the speaker to the system board.
5. Slide the speaker ❷ forward until it clears the system board.

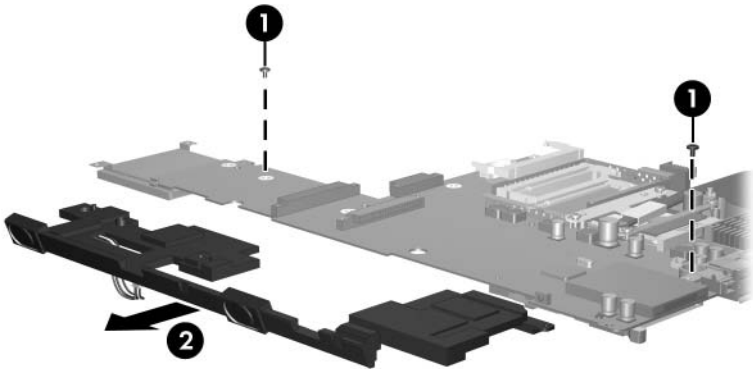

Removing the Speaker

Reverse the above procedure to install the speaker.

5.21 Heat Sink

Heat Sink Spare Part Number Information

Heat sink (includes thermal paste)

403827-001

1. Prepare the computer for disassembly ([Section 5.3](#)), and then remove the following components:
 - a. Hard drive ([Section 5.4](#))
 - b. Memory/Mini PCI module compartment cover ([Section 5.6](#))
 - c. Optical drive ([Section 5.9](#))
 - d. Switch cover ([Section 5.10](#))
 - e. Keyboard assembly frame ([Section 5.11](#))
 - f. Display assembly ([Section 5.14](#))
 - g. Top cover ([Section 5.15](#))
 - h. System board ([Section 5.16](#))

2. Turn the system board upside down with the expansion port 2 toward you.
3. Remove the four silver Phillips PM2.5×6.0 screws ❶ that secure the heat sink to the system board.
4. Remove the heat sink ❷.



Due to the adhesive quality of the thermal paste located between the heat sink and processor, it may be necessary to move the heat sink from side to side to detach the heat sink from the processor.

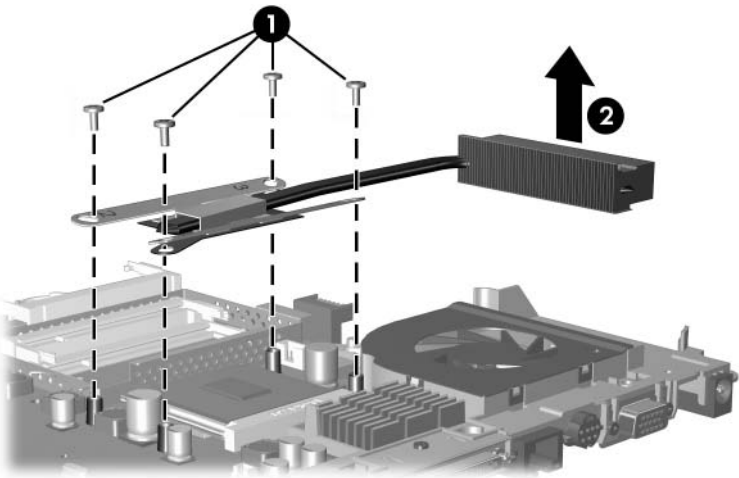

Removing the Heat Sink



The thermal paste should be thoroughly cleaned from the surfaces of the heat sink **1** and processor **2** each time the heat sink is removed. Thermal paste should be reapplied to both surfaces before the heat sink is reinstalled. Thermal paste is included with all heat sink and processor spare part kits.

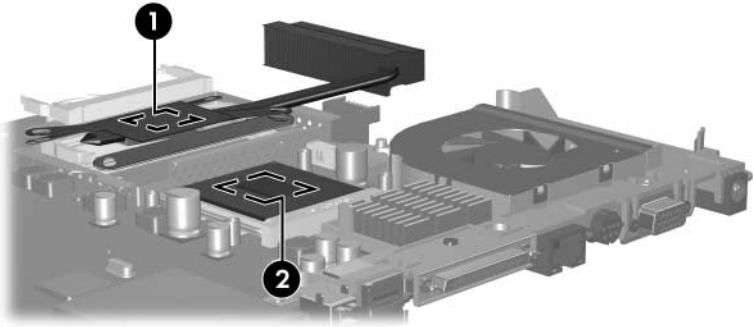

Replacing the Thermal Paste

Reverse the above procedure to install the heat sink.

5.22 Processor

Processor Spare Part Number Information

AMD Turion 64 ML-40 (2.2-GHz)	393579-001
AMD Turion 64 ML-37 (2.0-GHz)	393578-001
AMD Turion 64 ML-32 (1.8-GHz)	395744-001
AMD Turion 64 ML-30 (1.6-GHz)	395743-001



All processor spare part kits include thermal paste.

1. Prepare the computer for disassembly ([Section 5.3](#)), and then remove the following components:
 - a. Hard drive ([Section 5.4](#))
 - b. Memory/Mini PCI module compartment cover ([Section 5.6](#))
 - c. Optical drive ([Section 5.9](#))
 - d. Switch cover ([Section 5.10](#))
 - e. Keyboard assembly frame ([Section 5.11](#))
 - f. Display assembly ([Section 5.14](#))
 - g. Top cover ([Section 5.15](#))
 - h. System board ([Section 5.16](#))
 - i. Heat sink ([Section 5.21](#))

2. Slide the tip of the processor socket release arm **1** forward until it clears the notch **2** on the processor socket.
3. Swing the processor socket release arm forward **3** as far as it will go.
4. Lift the processor straight up and remove it **4**.



The gold triangle **5** on the processor should be aligned in the front right corner when you install the processor.

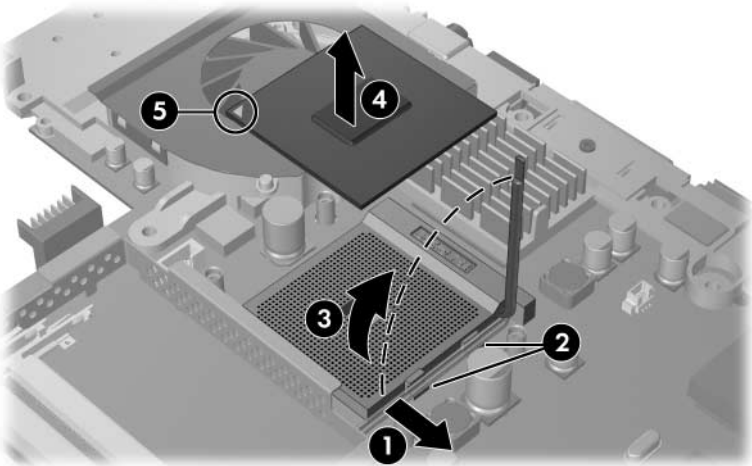

Removing the Processor

Reverse the above procedure to install the processor.

5.23 Fan Assembly

Fan Assembly Spare Part Number Information

Fan assembly

403826-001

1. Prepare the computer for disassembly ([Section 5.3](#)), and then remove the following components:
 - a. Hard drive ([Section 5.4](#))
 - b. Memory/Mini PCI module compartment cover ([Section 5.6](#))
 - c. Optical drive ([Section 5.9](#))
 - d. Switch cover ([Section 5.10](#))
 - e. Keyboard assembly frame ([Section 5.11](#))
 - f. Display assembly ([Section 5.14](#))
 - g. Top cover ([Section 5.15](#))
 - h. System board ([Section 5.16](#))
 - i. Heat sink ([Section 5.21](#))

2. Disconnect the fan cable ❶ and the power connector cable ❷ from the system board.
3. Remove the following screws:
 - ❸ One Phillips PM2.5×4.0 screw that secures the expansion port bracket and fan assembly to the system board
 - ❹ Two slotted M1.5×9.0 screws on each side of the expansion port 2 connector that secure the expansion port bracket and fan assembly to the system board
 - ❺ Two Phillips PM2.5×7.0 screws on each side of the external monitor connector that secure the fan assembly to the system board

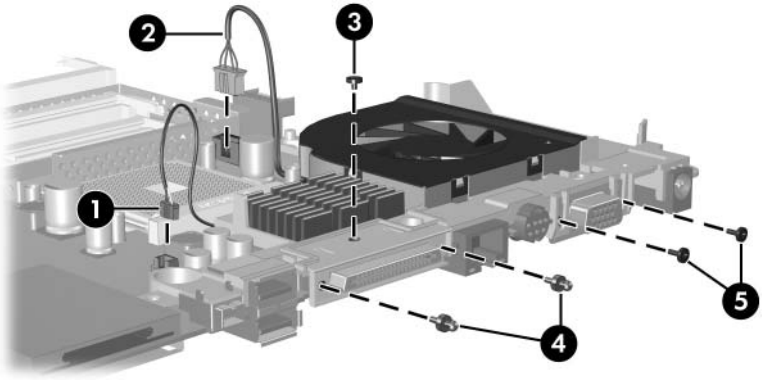

Removing the Fan Assembly Screws

4. Slide the expansion port 2 bracket **1** away from the system board.
5. Remove the fan assembly **2**.

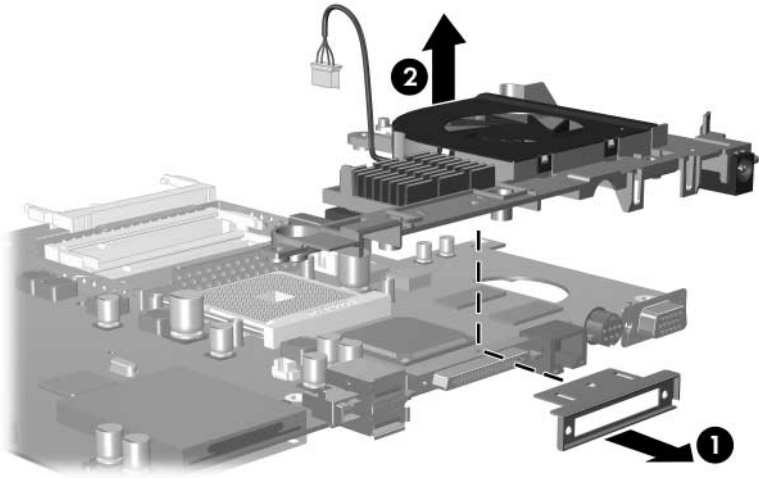

Removing the Fan Assembly



If necessary, perform the following steps to remove the power connector cable from the fan assembly.



The power connector cable is included in the Cable Kit, spare part number 403814-001.

6. Turn the fan assembly upside down with the power connector toward you.
7. Remove the power connector cable **1** from the routing channel on the fan assembly.
8. Remove the power connector **2** from the clip in the fan assembly.

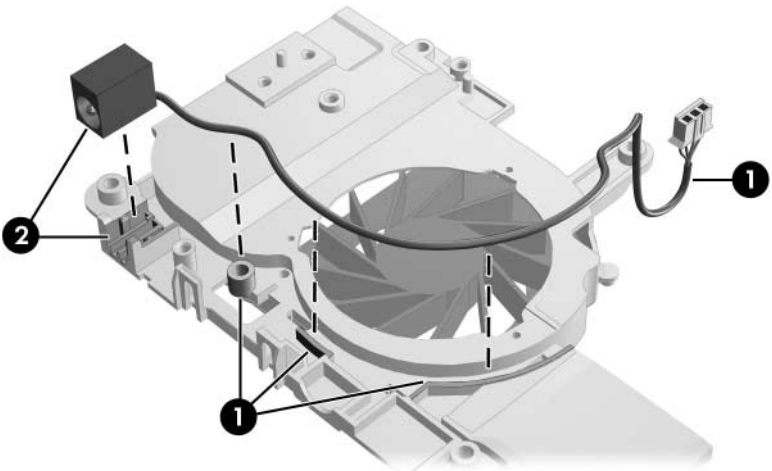

Removing the Power Connector Cable

Reverse the above procedure to install the power connector cable and fan assembly.

5.24 PC Card Assembly

PC Card Assembly Spare Part Number Information

PC Card assembly

403835-001

1. Prepare the computer for disassembly ([Section 5.3](#)), and then remove the following components:
 - a. Hard drive ([Section 5.4](#))
 - b. Memory/Mini PCI module compartment cover ([Section 5.6](#))
 - c. Optical drive ([Section 5.9](#))
 - d. Switch cover ([Section 5.10](#))
 - e. Keyboard assembly frame ([Section 5.11](#))
 - f. Display assembly ([Section 5.14](#))
 - g. Top cover ([Section 5.15](#))
 - h. System board ([Section 5.16](#))

2. Turn the system board upside down with the audio jacks, USB ports, and external monitor port toward you.
3. Remove the two Phillips PM2.0×4.0 screws that secure the PC Card assembly to the system board.

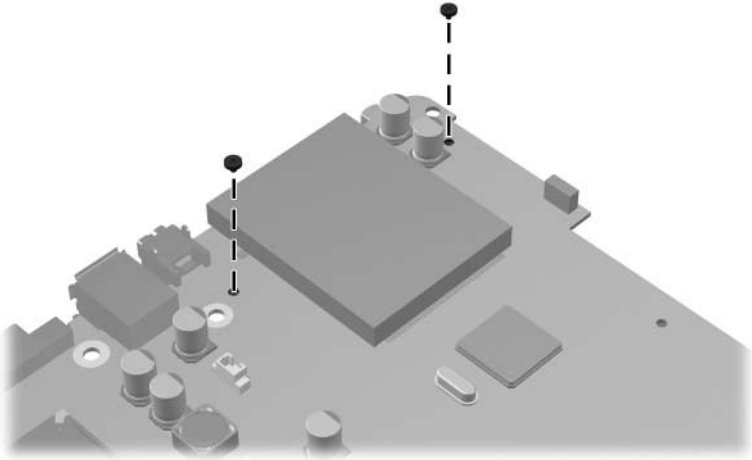

Removing the PC Card Assembly Screws

4. Turn the system board top-side up with the audio jacks, USB ports, and external monitor port toward you.
5. Disengage the hooks **1** on the PC Card assembly from the slots on the PC Card connector **2** and remove the PC Card assembly from the system board.

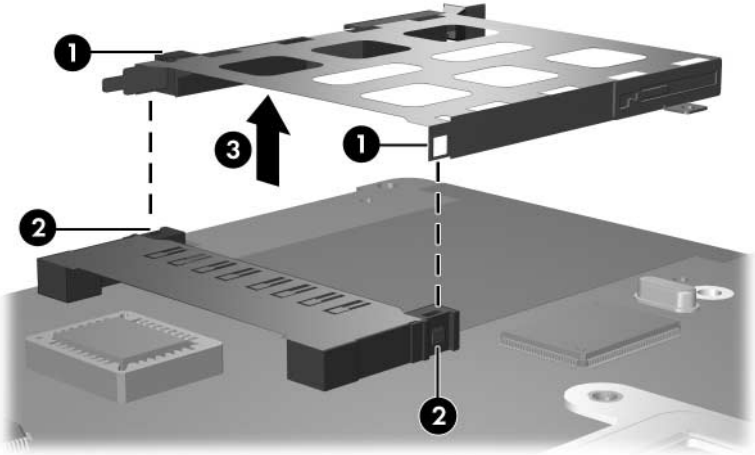

Removing the PC Card Assembly

Reverse the above procedures to install the PC Card assembly.

6

Specifications

This chapter provides physical and performance specifications.

Table 6-1
Computer

Dimensions	Metric	U.S.
Height		
Front	3.76 cm	1.48 in
Rear	4.62 cm	1.82 in
Width	39.68 cm	15.62 in
Depth	28.19 cm	11.10 in
Weight		
With 17.0-inch display, optical drive and 8-cell battery pack	3.62 kg	7.98 lbs
Input Power		
Operating voltage	18.5 V dc to 19.0 V dc	
Operating current	4.74 A or 4.9 A	
Temperature		
Operating	10°C to 35°C	50°F to 95°F
Nonoperating	-20°C to 60°C	-4°F to 140°F

Table 6-1
Computer (Continued)

Relative humidity (noncondensing)		
Operating	10% to 90%	10% to 90%
Nonoperating	5% to 95%	5% to 95%
Maximum altitude (unpressurized)		
Operating (14.7 to 10.1 psia)	-15 m to 3,048 m	-50 ft to 10,000 ft
Nonoperating (14.7 to 4.4 psia)	-15 m to 12,192 m	-50 ft to 40,000 ft
Shock		
Operating	125 g, 2 ms, half-sine	
Nonoperating	200 g, 2 ms, half-sine	
Random Vibration		
Operating	0.75 g zero-to-peak, 10 Hz to 500 Hz, 0.25 oct/min sweep rate	
Nonoperating	1.50 g zero-to-peak, 10 Hz to 500 Hz, 0.5 oct/min sweep rate	



Applicable product safety standards specify thermal limits for plastic surfaces. The computer operates well within this range of temperatures.

Table 6-2
17.0-inch, WSXGA+, BrightView Display

Dimensions		
Height	23.00 cm	9.06 in
Width	36.80 cm	14.49 in
Diagonal	43.40 cm	17.09 in
Number of colors		Up to 16.8 million
Contrast ratio		200:1
Brightness		180 nits typical
Pixel resolution		
Pitch	0.197 × 0.197 mm	
Format	1680 × 1050	
Configuration	RGB vertical stripe	
Backlight		Edge lit
Character display		80 × 25
Total power consumption		4 W
Viewing angle		+/-65° horizontal, +50° vertical typical

Table 6-3
17.0-inch, WXGA+, BrightView Display

Dimensions		
Height	23.00 cm	9.06 in
Width	36.80 cm	14.49 in
Diagonal	43.40 cm	17.09 in
Number of colors		Up to 16.8 million
Contrast ratio		200:1
Brightness		180 nits typical
Pixel resolution		
Pitch	0.259 × 0.259 mm	
Format	1280 × 800	
Configuration	RGB vertical stripe	
Backlight		Edge lit
Character display		80 × 25
Total power consumption		4 W
Viewing angle		+/-40° horizontal, +20/-40° vertical typical

Table 6-4
Hard Drives

	100-GB*	80-GB*	80-GB*
Dimensions			
Height	9.5 mm	9.5 mm	9.5 mm
Width	70 mm	70 mm	70 mm
Weight	102 g	99 g	99 g
Interface type			
	ATA-5	ATA-5	ATA-5
Transfer rate			
Synchronous (maximum)	100 MB/sec	100 MB/sec	100 MB/sec
Security	ATA security	ATA security	ATA security
Seek times (typical read, including setting)			
Single track	3 ms	3 ms	3 ms
Average	13 ms	13 ms	13 ms
Maximum	24 ms	24 ms	24 ms
Logical blocks [†]			
	195,364,233	156,301,488	156,301,488
Disc rotational speed			
	4200 rpm	5400 rpm	4200 rpm
Operating temperature			
	5°C to 55°C (41°F to 131°F)		



Certain restrictions and exclusions apply. Consult Customer Care for details.

*1 GB = 1 billion bytes when referring to hard drive storage capacity. Actual accessible capacity is less.

[†]Actual drive specifications may differ slightly.

Table 6-4
Hard Drives (Continued)

	60-GB*	60-GB*	40-GB*
Dimensions			
Height	9.5 mm	9.5 mm	9.5 mm
Width	70 mm	70 mm	70 mm
Weight	102 g	99 g	99 g
Interface type	ATA-5	ATA-5	ATA-5
Transfer rate			
Synchronous (maximum)	100 MB/sec	100 MB/sec	100 MB/sec
Security	ATA security	ATA security	ATA security
Seek times (typical read, including setting)			
Single track	3 ms	3 ms	3 ms
Average	13 ms	13 ms	13 ms
Maximum	24 ms	24 ms	24 ms
Logical blocks[†]	117,210,240	117,210,240	78,140,160
Disc rotational speed	5400 rpm	4200 rpm	4200 rpm
Operating temperature	5°C to 55°C (41°F to 131°F)		

 Certain restrictions and exclusions apply. Consult Customer Care for details.

*1 GB = 1 billion bytes when referring to hard drive storage capacity. Actual accessible capacity is less.

[†]Actual drive specifications may differ slightly.

Table 6-5
Primary 8-cell, Li-Ion Battery Pack

Dimensions

Height	2.00 cm	0.79 in
Width	9.40 cm	3.70 in
Depth	13.40 cm	5.28 in
Weight	0.34 kg	0.75 lb

Energy

Voltage	11.1 V
Amp-hour capacity	4.4 Ah
Watt-hour capacity	48 Wh

Temperature

Operating	5°C to 45°C	41°F to 113°F
Nonoperating	0°C to 60°C	32°F to 140°F

Table 6-6
DVD/CD-RW Combo Drive

Applicable disc	Read: DVD-R, DVD-RW, DVD-ROM (DVD-5, DVD-9, DVD-10, DVD-18), CD-ROM (Mode 1 and 2) CD Digital Audio, CD-XA ready (Mode 2, Form 1 and 2), CD-I ready (Mode 2, Form 1 and 2), CD-R, CD-RW, Photo CD (single and multisession), and CD-Bridge	Write: CD-R and CD-RW
Center hole diameter	1.5 cm (0.59 in)	
Disc diameter		
Standard disc	12 cm (4.72 in)	
Mini disc	8 cm (3.15 in)	
Disc thickness	1.2 mm (0.047 in)	
Track pitch	0.74 μ m	
Access time	CD media	DVD media
Random	< 110 ms	< 130 ms
Full stroke	< 210 ms	< 225 ms
Audio output level	Line-out, 0.7 V rms	
Cache buffer	2 MB	
Data transfer rate		
CD-R (24X)	3600 KB/s (150 KB/s at 1X CD rate)	
CD-RW (10X)	1500 KB/s (150 KB/s at 1X CD rate)	
CD-ROM (24X)	3600 KB/s (150 KB/s at 1X CD rate)	
DVD (8X)	10,800 KB/s (1352 KB/s at 1X DVD rate)	
Multiword DMA mode 2	16.6 MB/s	
Startup time	< 15 seconds	
Stop time	< 6 seconds	

Table 6-7

DVD±RW and CD-RW Double Layer Combo Drive

Applicable disc	Read: DVD-R, DVD-RW, DVD-ROM (DVD-5, DVD-9, DVD-10, DVD-18), CD-ROM (Mode 1 and 2), CD Digital Audio, CD-XA ready (Mode 2, Form 1 and 2), CD-I ready (Mode 2, Form 1 and 2), CD-R, CD-RW, Photo CD (single and multisession), CD-Bridge	Write: CD-R and CD-RW DVD-R and DVD-RW
Center hole diameter	1.5 cm (0.59 in)	
Disc diameter		
Standard disc	12 cm (4.72 in)	
Mini disc	8 cm (3.15 in)	
Disc thickness	1.2 mm (0.047 in)	
Track pitch	0.74 μ m	
Access time	CD	DVD
Random	< 175 ms	< 230 ms
Full stroke	< 285 ms	< 335 ms
Audio output level	Audio-out, 0.7 Vrms	
Cache buffer	2 MB	

Table 6-7

DVD±RW and CD-RW Double Layer Combo Drive (Continued)

Data transfer rate

CD-R (16X)	2,400 KB/s (150 KB/s at 1X CD rate)
CD-RW (8X)	1,200 KB/s (150 KB/s at 1X CD rate)
CD-ROM (24X)	3,600 KB/s (150 KB/s at 1X CD rate)
DVD (8X)	10,800 KB/s (1,352 KB/s at 1X DVD rate)
DVD-R (4X)	5,400 KB/s (1,352 KB/s at 1X DVD rate)
DVD-RW (2X)	2,700 KB/s (1,352 KB/s at 1X DVD rate)
Multiword DMA mode 2	16.6 MB/s

Startup time < 15 seconds

Stop time < 6 seconds

Table 6-8

**DVD±RW and CD-RW Double Layer Combo Drive
with LightScribe**

Applicable disc	Read: DVD-R, DVD-RW, DVD-ROM (DVD-5, DVD-9, DVD-10, DVD-18), CD-ROM (Mode 1 and 2), CD Digital Audio, CD-XA ready (Mode 2, Form 1 and 2), CD-I ready (Mode 2, Form 1 and 2), CD-R, CD-RW, Photo CD (single and multisession), CD-Bridge	Write: CD-R and CD-RW DVD-R and DVD-RW
------------------------	---	--

Center hole diameter 1.5 cm (0.59 in)

Disc diameter

Standard disc	12 cm (4.72 in)
Mini disc	8 cm (3.15 in)

Table 6-8
DVD±RW and CD-RW Double Layer Combo Drive
with LightScribe (Continued)

Disc thickness	1.2 mm (0.047 in)	
Track pitch	0.74 μm	
Access time	CD	DVD
Random	< 175 ms	< 230 ms
Full stroke	< 285 ms	< 335 ms
Audio output level	Audio-out, 0.7 Vrms	
Cache buffer	2 MB	
Data transfer rate		
CD-R (16X)	2,400 KB/s (150 KB/s at 1X CD rate)	
CD-RW (8X)	1,200 KB/s (150 KB/s at 1X CD rate)	
CD-ROM (24X)	3,600 KB/s (150 KB/s at 1X CD rate)	
DVD (8X)	10,800 KB/s (1,352 KB/s at 1X DVD rate)	
DVD-R (4X)	5,400 KB/s (1,352 KB/s at 1X DVD rate)	
DVD-RW (2X)	2,700 KB/s (1,352 KB/s at 1X DVD rate)	
Multiword DMA mode 2	16.6 MB/s	
Startup time	< 15 seconds	
Stop time	< 6 seconds	

Table 6-9
System DMA

Hardware DMA	System Function
DMA0	Not applicable
DMA1*	Not applicable
DMA2*	Not applicable
DMA3	Not applicable
DMA4	Direct memory access controller
DMA5*	Available for PC Card
DMA6	Not assigned
DMA7	Not assigned

*PC Card controller can use DMA 1, 2, or 5.

Table 6-10
System Interrupts

Hardware IRQ	System Function
IRQ0	System timer
IRQ1	Standard 101-/102-Key or Microsoft Natural Keyboard
IRQ2	Cascaded
IRQ3	USB2 Enhanced Host Controller—24CD
IRQ4	COM1
IRQ5*	Conexant AC—Link Audio Data Fax Modem with SmartCP
IRQ6	Diskette drive
IRQ7*	Parallel port
IRQ8	System CMOS/real-time clock
IRQ9*	Microsoft ACPI-compliant system
IRQ10*	Realtek RTL8139 Family PCI fast Ethernet Controller

Table 6-10
System Interrupts (*Continued*)

IRQ11	TI OHCI 1394 host controller TI PCI1410 CardBus controller
IRQ12	Synaptics PS/2 TouchPad
IRQ13	Numeric data processor
IRQ14	Primary IDE channel
IRQ15	Secondary IDE channel

*Default configuration; audio possible configurations are IRQ5, IRQ7, IRQ9, IRQ10, or none.



PC Cards may assert IRQ3, IRQ4, IRQ5, IRQ7, IRQ9, IRQ10, IRQ11, or IRQ15. Either the infrared or the serial port may assert IRQ3 or IRQ4.

Table 6-11
System I/O Addresses

I/O Address (hex)	System Function (shipping configuration)
000 - 00F	DMA controller no. 1
010 - 01F	Unused
020 - 021	Interrupt controller no. 1
022 - 024	Opti chipset configuration registers
025 - 03F	Unused
02E - 02F	87334 "Super I/O" configuration for CPU
040 - 05F	Counter/timer registers
044 - 05F	Unused
060	Keyboard controller
061	Port B
062 - 063	Unused
064	Keyboard controller
065 - 06F	Unused
070 - 071	NMI enable/RTC
072 - 07F	Unused
080 - 08F	DMA page registers
090 - 091	Unused
092	Port A
093 - 09F	Unused
0A0 - 0A1	Interrupt controller no. 2

Table 6-11
System I/O Addresses (Continued)

I/O Address (hex)	System Function (shipping configuration)
0A2 - 0BF	Unused
0C0 - 0DF	DMA controller no. 2
0E0 - 0EF	Unused
0F0 - 0F1	Coprocessor busy clear/reset
0F2 - 0FF	Unused
100 - 16F	Unused
170 - 177	Secondary fixed disk controller
178 - 1EF	Unused
1F0 - 1F7	Primary fixed disk controller
1F8 - 200	Unused
201	Joystick (decoded in ESS1688)
202 - 21F	Unused
220 - 22F	Entertainment audio
230 - 26D	Unused
26E - 26	Unused
278 - 27F	Unused
280 - 2AB	Unused
2A0 - 2A7	Unused
2A8 - 2E7	Unused
2E8 - 2EF	Reserved serial port

Table 6-11
System I/O Addresses (Continued)

I/O Address (hex)	System Function (shipping configuration)
2F0 - 2F7	Unused
2F8 - 2FF	Infrared port
300 - 31F	Unused
320 - 36F	Unused
370 - 377	Secondary diskette drive controller
378 - 37F	Parallel port (LPT1/default)
380 - 387	Unused
388 - 38B	FM synthesizer—OPL3
38C - 3AF	Unused
3B0 - 3BB	VGA
3BC - 3BF	Reserved (parallel port/no EPP support)
3C0 - 3DF	VGA
3E0 - 3E1	PC Card controller in CPU
3E2 - 3E3	Unused
3E8 - 3EF	Internal modem
3F0 - 3F7	“A” diskette controller
3F8 - 3FF	Serial port (COM1/default)
CF8 - CFB	PCI configuration index register (PCIDIVO-1)
CFC - CFF	PCI configuration data register (PCIDIVO-1)

Table 6-12
System Memory Map

Size	Memory Address	System Function
640 KB	00000000-0009FFFF	Base memory
128 KB	000A0000-000BFFFF	Video memory
48 KB	000C0000-000CBFFF	Video BIOS
160 KB	000C8000-000E7FFF	Unused
64 KB	000E8000-000FFFFF	System BIOS
15 MB	00100000-00FFFFFF	Extended memory
58 MB	01000000-047FFFFF	Super extended memory
58 MB	04800000-07FFFFFF	Unused
2 MB	08000000-080FFFFF	Video memory (direct access)
4 GB	08200000-FFFEFFFF	Unused
64 KB	FFFF0000-FFFFFFFF	System BIOS

A

Connector Pin Assignments

Table A-1
Audio-Out (Headphone)

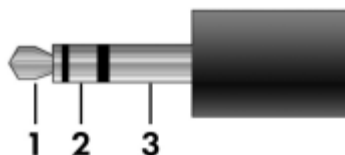

Pin	Signal	Pin	Signal
1	Audio out, left channel	3	Ground
2	Audio out, right channel		

Table A-2
Audio-In (Microphone)

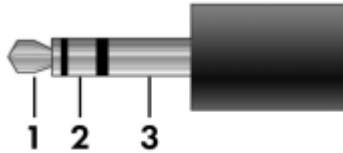

Pin	Signal	Pin	Signal
1	Audio signal in	3	Ground
2	Audio signal in		

Table A-3
Universal Serial Bus

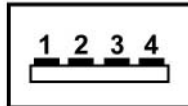

Pin	Signal	Pin	Signal
1	+5 VDC	3	Data +
2	Data -	4	Ground

Table A-4
External Monitor

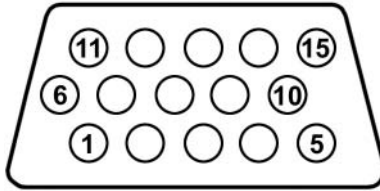

Pin	Signal	Pin	Signal
1	Red analog	9	+5 VDC
2	Green analog	10	Ground
3	Blue analog	11	Monitor detect
4	Not connected	12	DDC 2B data
5	Ground	13	Horizontal sync
6	Ground analog	14	Vertical sync
7	Ground analog	15	DDC 2B clock
8	Ground analog		

Table A-5
RJ-45 (Network)

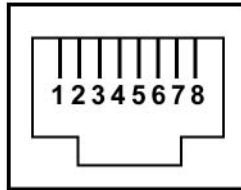

Pin	Signal	Pin	Signal
1	Transmit +	5	Unused
2	Transmit –	6	Receive –
3	Receive +	7	Unused
4	Unused	8	Unused

Table A-6
RJ-11 (Modem)

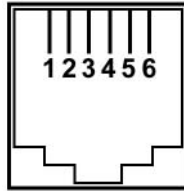

Pin	Signal	Pin	Signal
1	Unused	4	Unused
2	Tip	5	Unused
3	Ring	6	Unused

Table A-7
S-Video-Out



Pin	Signal	Pin	Signal
1	S-VHS color (C) signal	5	TV-CD
2	Composite video signal	6	S-VHS intensity ground
3	S-VHS intensity (Y) signal	7	Composite video ground
4	S-VHS color ground		

Power Cord Set Requirements

3-Conductor Power Cord Set

The wide range input feature of the computer permits it to operate from any line voltage from 100 to 120 or 220 to 240 volts AC.

The power cord set included with the computer meets the requirements for use in the country where the equipment is purchased.

Power cord sets for use in other countries must meet the requirements of the country where the computer is used.

General Requirements

The requirements listed below are applicable to all countries.

- The length of the power cord set must be at least 1.5 m (5.0 ft) and a maximum of 2.0 m (6.5 ft).
- All power cord sets must be approved by an acceptable accredited agency responsible for evaluation in the country where the power cord set will be used.
- The power cord sets must have a minimum current capacity of 10 amps and a nominal voltage rating of 125 or 250 V AC, as required by each country's power system.
- The appliance coupler must meet the mechanical configuration of an EN 60 320/IEC 320 Standard Sheet C13 connector for mating with the appliance inlet on the back of the computer.

Country-Specific Requirements

3-Conductor Power Cord Set Requirements

Country/Region	Accredited Agency	Applicable Note Number
Australia	EANSW	1
Austria	OVE	1
Belgium	CEBC	1
Canada	CSA	2
Denmark	DEMKO	1
Finland	FIMKO	1
France	UTE	1
Germany	VDE	1
Italy	IMQ	1
Japan	METI	3



NOTES:

1. The flexible cord must be <HAR> Type HO5VV-F, 3-conductor, 1.0 mm² conductor size. Power cord set fittings (appliance coupler and wall plug) must bear the certification mark of the agency responsible for evaluation in the country where it will be used.
2. The flexible cord must be Type SPT-3 or equivalent, No. 18 AWG, 3-conductor. The wall plug must be a two-pole grounding type with a NEMA 5-15P (15 A, 125 V) or NEMA 6-15P (15 A, 250 V) configuration.
3. The appliance coupler, flexible cord, and wall plug must bear a "T" mark and registration number in accordance with the Japanese Dentori Law. The flexible cord must be Type VCT or VCTF, 3-conductor, 1.00 mm² conductor size. The wall plug must be a two-pole grounding type with a Japanese Industrial Standard C8303 (7 A, 125 V) configuration.

3-Conductor Power Cord Set Requirements (*Continued*)

Country/Region	Accredited Agency	Applicable Note Number
Korea	EK	4
The Netherlands	KE A	1
Norway	NEMKO	1
People's Republic of China	CCC	5
Sweden	SEMKO	1
Switzerland	SEV	1
Taiwan	BSMI	4
United Kingdom	BSI	1
United States	UL	2



NOTES:

1. The flexible cord must be <HAR> Type HO5VV-F, 3-conductor, 1.0 mm² conductor size. Power cord set fittings (appliance coupler and wall plug) must bear the certification mark of the agency responsible for evaluation in the country where it will be used.
2. The flexible cord must be Type SPT-3 or equivalent, No. 18 AWG, 3-conductor. The wall plug must be a two-pole grounding type with a NEMA 5-15P (15 A, 125 V) or NEMA 6-15P (15 A, 250 V) configuration.
3. The appliance coupler, flexible cord, and wall plug must bear a “T” mark and registration number in accordance with the Japanese Dentori Law. The flexible cord must be Type VCT or VCTF, 3-conductor, 1.00 mm² conductor size. The wall plug must be a two-pole grounding type with a Japanese Industrial Standard C8303 (7 A, 125 V) configuration.
4. The flexible cord must be Type RVV, 3-conductor, 0.75 mm² conductor size. Power cord set fittings (appliance coupler and wall plug) must bear the certification mark of the agency responsible for evaluation in the country where it will be used.
5. The flexible cord must be Type VCTF, 3-conductor, 0.75 mm² conductor size. Power cord set fittings (appliance coupler and wall plug) must bear the certification mark of the agency responsible for evaluation in the country where it will be used.

Screw Listing

This appendix provides specification and reference information for the screws and screw locks used in the computer. All screws listed in this appendix are available in the Computer Screw Kit, spare part number 403813-001, and the Display Screw Kit, spare part number 403886-001.

Table C-1

Phillips PM3.0x4.0 Screw

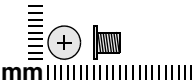
	Color	Qty.	Length	Thread	Head Width
	Black	4	4.0 mm	3.0 mm	4.5 mm

Where used:

4 screws that secure the hard drive frame to the hard drive (documented in [Section 5.4](#))

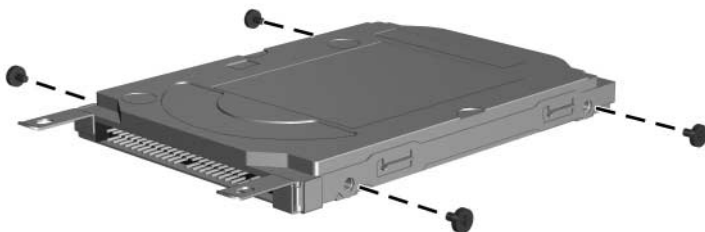

Phillips PM3.0x4.0 Screw Locations

Table C-2
Black Phillips PM2.5×6.0 Screw

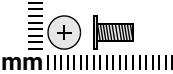
 mm	Color	Qty.	Length	Thread	Head Width
	Black	5	6.0 mm	2.5 mm	5.0 mm

Where used:

- ❶ Three screws that secure the hard drive cover to the computer (screws are captured on the cover by C clips; documented in [Section 5.4](#))
- ❷ Two screws that secure the memory/Mini PCI module compartment cover to the computer (screw is captured on the cover by C clips; documented in [Section 5.6](#))

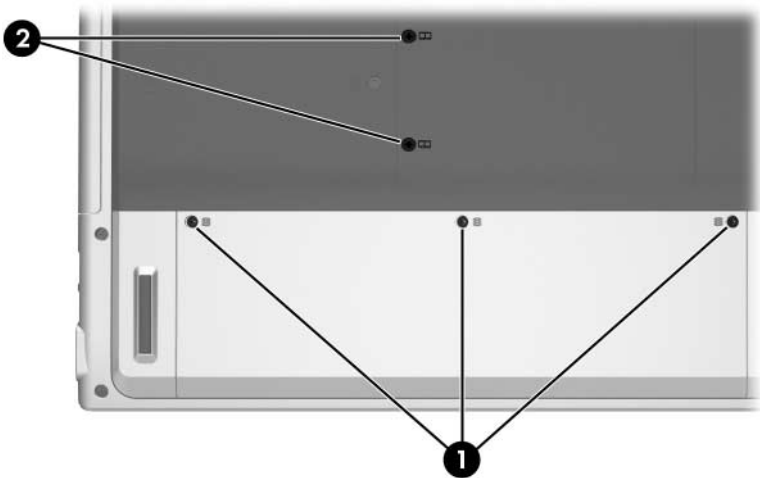

Black Phillips PM2.5×6.0 Screw Locations

Table C-3
Silver Phillips PM2.5×6.0 Screw

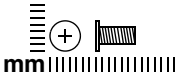
	Color	Qty.	Length	Thread	Head Width
mm	Silver	29	6.0 mm	2.5 mm	4.5 mm

Where used:

4 screws that secure the hard drive to the computer (documented in [Section 5.4](#))

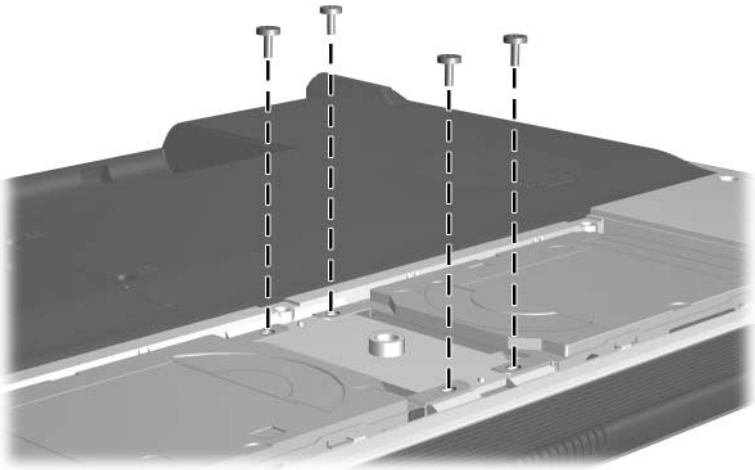

Silver Phillips PM2.5×6.0 Screw Locations

Table C-3

Silver Phillips PM2.5x6.0 Screw (Continued)

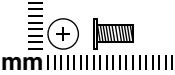
	Color	Qty.	Length	Thread	Head Width
	Silver	29	6.0 mm	2.5 mm	4.5 mm

Where used:

One screw that secures the keyboard assembly to the computer (documented in [Section 5.11](#))



Silver Phillips PM2.5x6.0 Screw Location

Table C-3

Silver Phillips PM2.5×6.0 Screw (*Continued*)

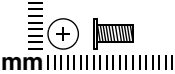
	Color	Qty.	Length	Thread	Head Width
	Silver	29	6.0 mm	2.5 mm	4.5 mm

Where used:

One screw that secures the display assembly to the computer (documented in [Section 5.14](#))

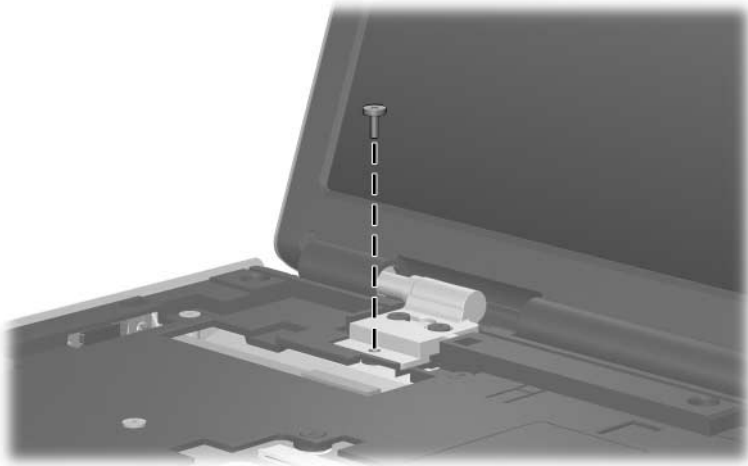

Silver Phillips PM2.5×6.0 Screw Location

Table C-3

Silver Phillips PM2.5×6.0 Screw (Continued)

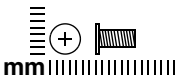
	Color	Qty.	Length	Thread	Head Width
	Silver	29	6.0 mm	2.5 mm	4.5 mm

Where used:

3 screws that secure the top cover to the computer (documented in [Section 5.15](#))

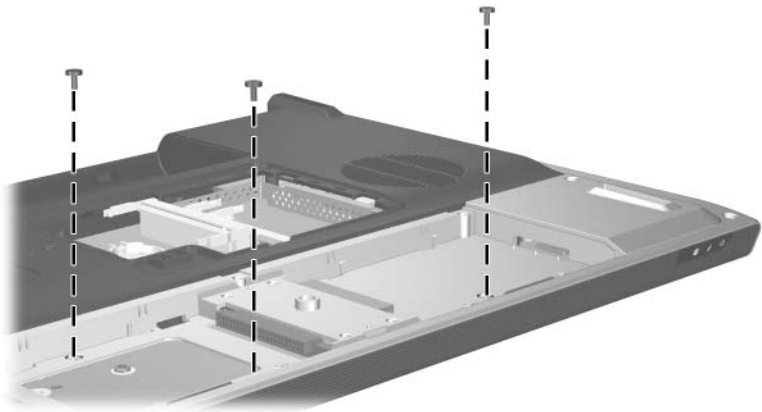

Silver Phillips PM2.5×6.0 Screw Locations

Table C-3
Silver Phillips PM2.5×6.0 Screw (Continued)

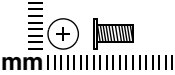
	Color	Qty.	Length	Thread	Head Width
	Silver	29	6.0 mm	2.5 mm	4.5 mm

Where used:

8 screws that secure the top cover to the computer (documented in [Section 5.15](#))

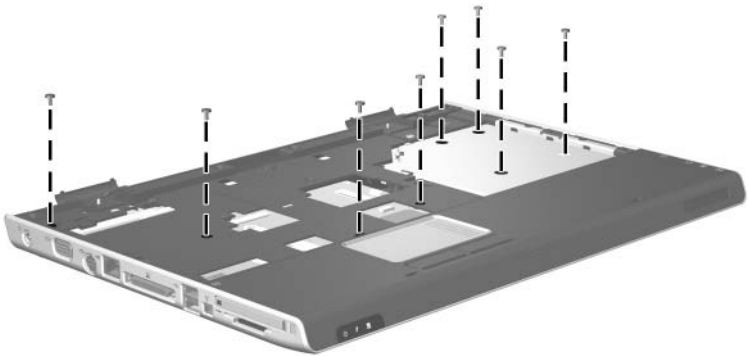

Silver Phillips PM2.5×6.0 Screw Locations

Table C-3
Silver Phillips PM2.5×6.0 Screw (Continued)

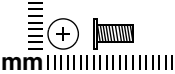
	Color	Qty.	Length	Thread	Head Width
	Silver	29	6.0 mm	2.5 mm	4.5 mm

Where used:

2 screws that secure the base enclosure support bracket to the computer (documented in [Section 5.16](#))

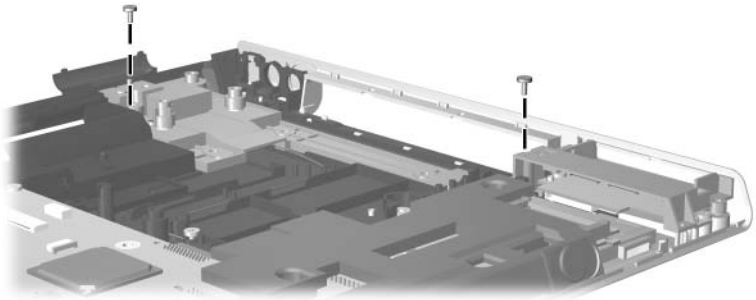

Silver Phillips PM2.5×6.0 Screw Locations

Table C-3
Silver Phillips PM2.5×6.0 Screw (Continued)

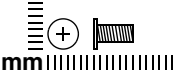
	Color	Qty.	Length	Thread	Head Width
	Silver	29	6.0 mm	2.5 mm	4.5 mm

Where used:

4 screws that secure the system board to the computer (documented in [Section 5.16](#))

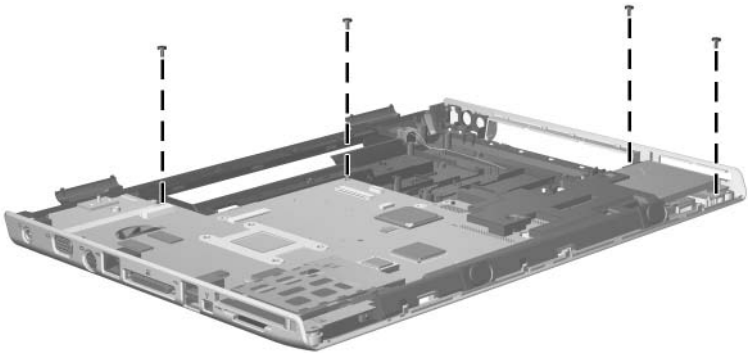

Silver Phillips PM2.5×6.0 Screw Locations

Table C-3
Phillips PM2.5x4.0 Screw (Continued)

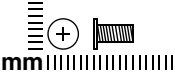
	Color	Qty.	Length	Thread	Head Width
mm	Silver	29	6.0 mm	2.5 mm	4.5 mm

Where used:

2 screws that secure the speaker to the computer (documented in [Section 5.20](#))

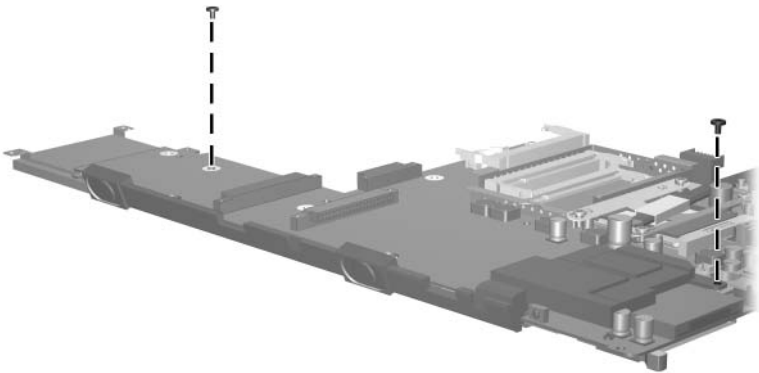

Phillips PM2.5x6.0 Screw Locations

Table C-3
Silver Phillips PM2.5×6.0 Screw (Continued)

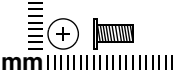
	Color	Qty.	Length	Thread	Head Width
	Silver	29	6.0 mm	2.5 mm	4.5 mm

Where used:

4 screws that secure the heat sink to the computer (documented in [Section 5.21](#))

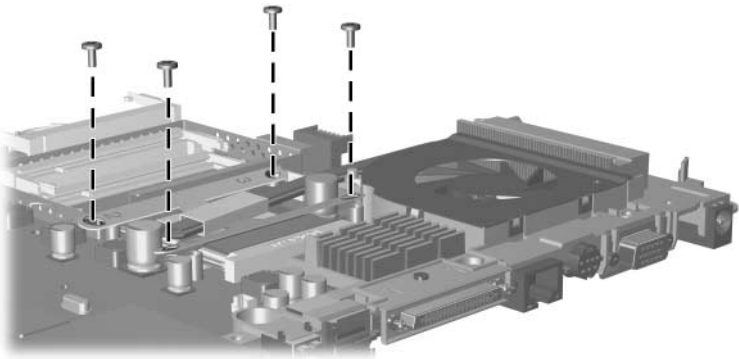

Silver Phillips PM2.5×6.0 Screw Locations

Table C-4
Phillips PM2.5×4.0 Screw

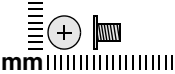
 mm	Color	Qty.	Length	Thread	Head Width
	Black	20	4.0 mm	2.5 mm	4.5 mm

Where used:

2 screws that secure the memory shield to the computer (documented in [Section 5.6](#))

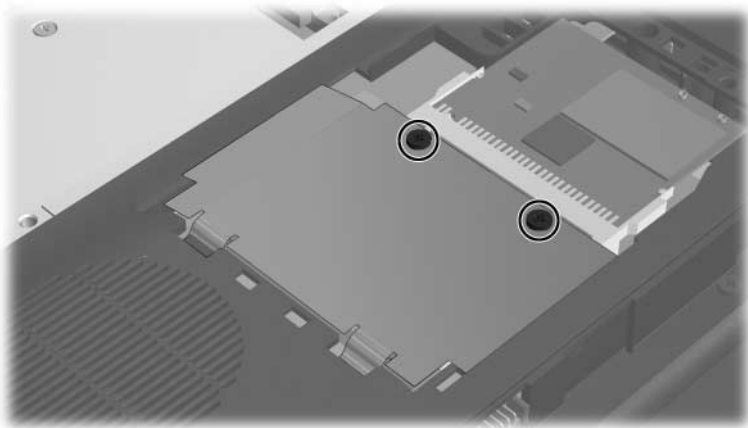

Phillips PM2.5×4.0 Screw Locations

Table C-4
Phillips PM2.5×4.0 Screw (Continued)

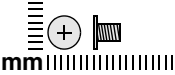
	Color	Qty.	Length	Thread	Head Width
	Black	20	4.0 mm	2.5 mm	4.5 mm

Where used:

3 screws that secure the switch cover to the computer (documented in [Section 5.10](#))

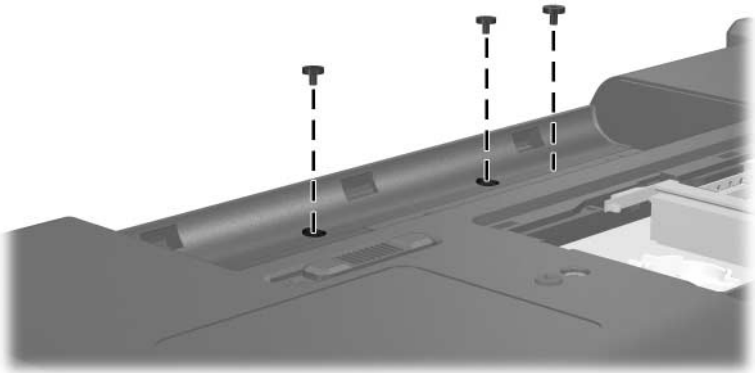

Phillips PM2.5×4.0 Screw Locations

Table C-4

Phillips PM2.5×4.0 Screw (Continued)

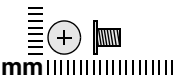
	Color	Qty.	Length	Thread	Head Width
	Black	20	4.0 mm	2.5 mm	4.5 mm

Where used:

- ❶ Four screws that secure the LED board to the keyboard frame (documented in [Section 5.12](#))
- ❷ Five screws that secure the keyboard to the keyboard frame (documented in [Section 5.13](#))

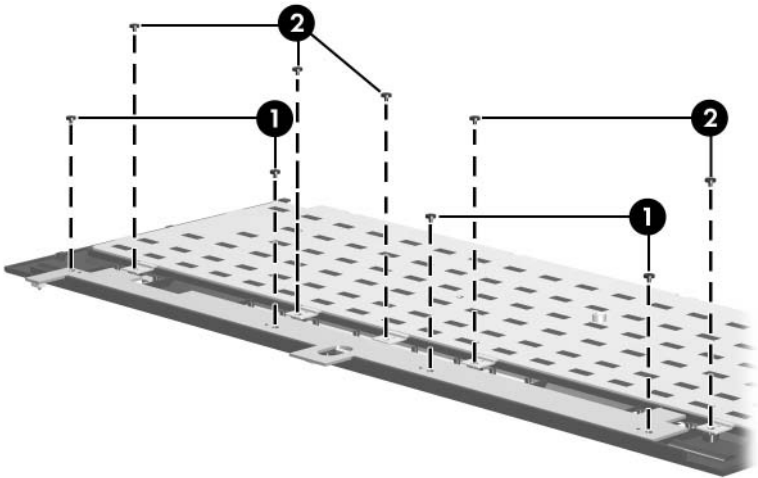

Phillips PM2.5×4.0 Screw Locations

Table C-4
Phillips PM2.5×4.0 Screw (Continued)

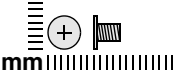
	Color	Qty.	Length	Thread	Head Width
	Black	20	4.0 mm	2.5 mm	4.5 mm

Where used:

2 screws that secure the display panel to the display enclosure (documented in [Section 5.14](#))

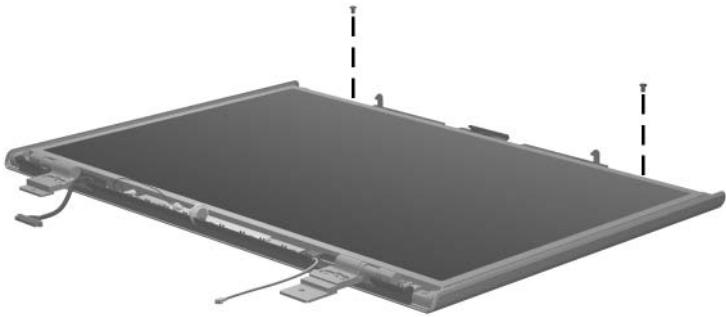

Phillips PM2.5×4.0 Screw Locations

Table C-4
Phillips PM2.5×4.0 Screw (Continued)

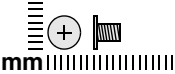
	Color	Qty.	Length	Thread	Head Width
	Black	20	4.0 mm	2.5 mm	4.5 mm

Where used:

2 screws that secure the top cover to the computer (documented in [Section 5.15](#))

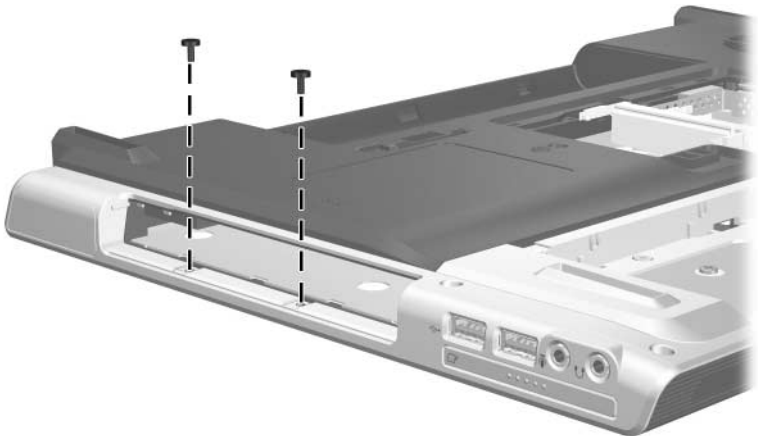

Phillips PM2.5×4.0 Screw Locations

Table C-4

Phillips PM2.5x4.0 Screw (*Continued*)

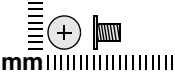
	Color	Qty.	Length	Thread	Head Width
	Black	20	4.0 mm	2.5 mm	4.5 mm

Where used:

One screw that secures the connector board to the computer (documented in [Section 5.16](#))

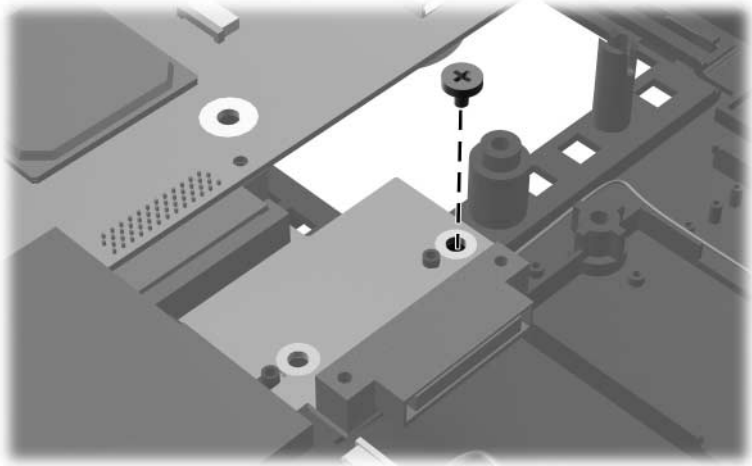

Phillips PM2.5x4.0 Screw Location

Table C-4
Phillips PM2.5x4.0 Screw (Continued)

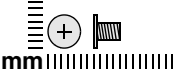
	Color	Qty.	Length	Thread	Head Width
	Black	20	4.0 mm	2.5 mm	4.5 mm

Where used:

One screw that secures the fan assembly and expansion port bracket to the system board (documented in [Section 5.23](#))

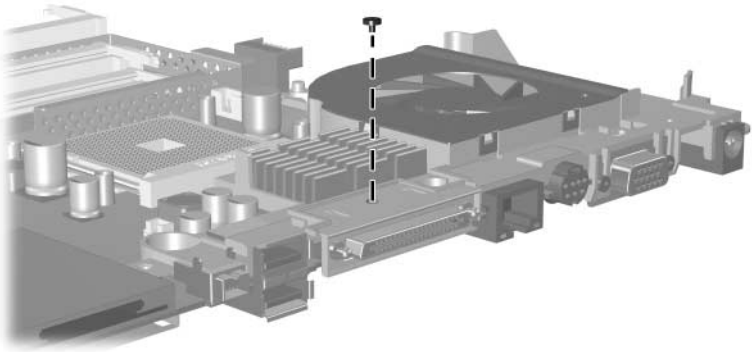

Phillips PM2.5x4.0 Screw Location

Table C-5
Phillips PM2.5×13.0 Screw

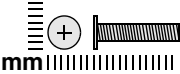
 mm	Color	Qty.	Length	Thread	Head Width
	Black	15	13.0 mm	2.5 mm	4.5 mm

Where used:

- ❶ One screw that secures the optical drive to the computer (documented in [Section 5.9](#))
- ❷ Two screws that secure the switch cover to the computer (documented in [Section 5.10](#))

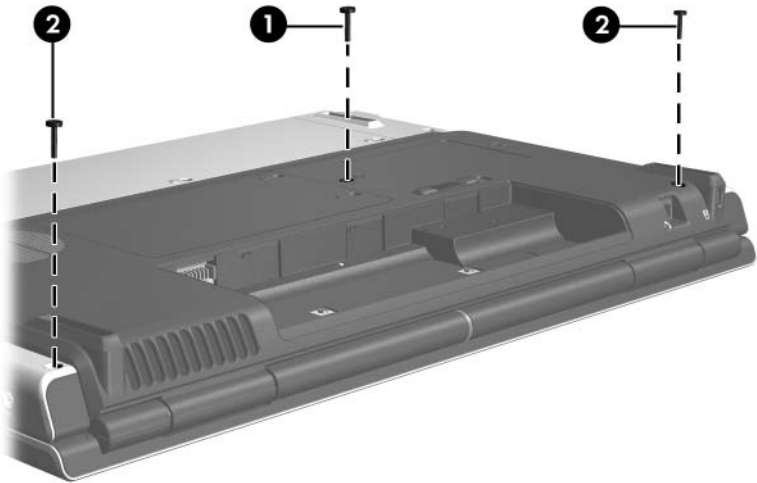

Phillips PM2.5×13.0 Screw Locations

Table C-5
Phillips PM2.5×13.0 Screw (Continued)

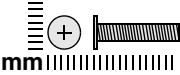
	Color	Qty.	Length	Thread	Head Width
	Black	15	13.0 mm	2.5 mm	4.5 mm

Where used:

One screw that secures the keyboard assembly to the computer (documented in [Section 5.11](#))

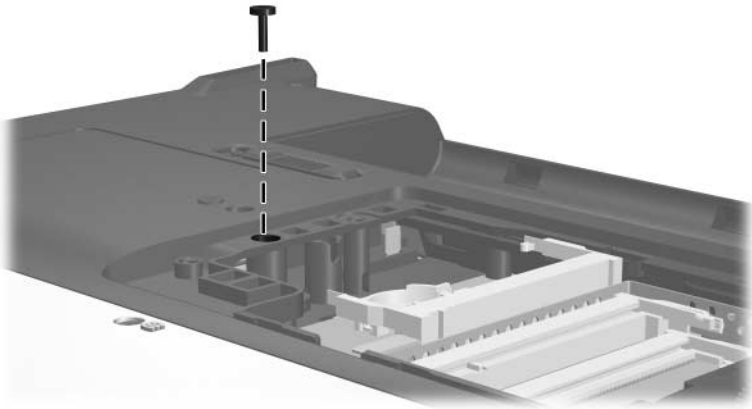

Phillips PM2.5×13.0 Screw Location

Table C-5
Phillips PM2.5×13.0 Screw (Continued)

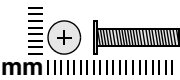
	Color	Qty.	Length	Thread	Head Width
	Black	15	13.0 mm	2.5 mm	4.5 mm

Where used:

5 screws that secure the top cover to the computer (documented in [Section 5.15](#))

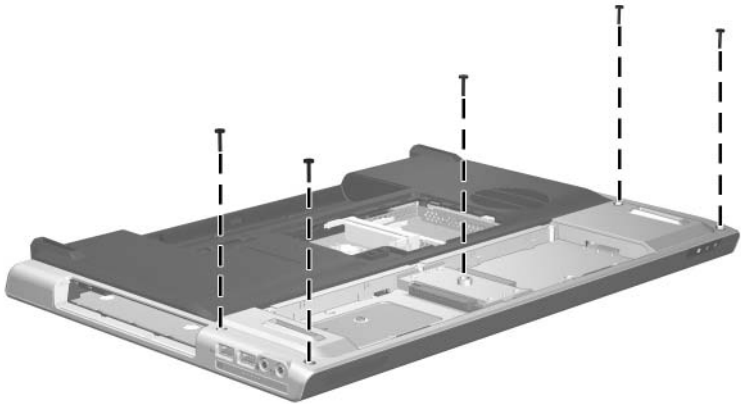

Phillips PM2.5×13.0 Screw Locations

Table C-5

Phillips PM2.5×13.0 Screw (Continued)

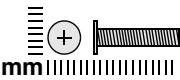
	Color	Qty.	Length	Thread	Head Width
	Black	15	13.0 mm	2.5 mm	4.5 mm

Where used:

6 screws that secure the top cover to the computer (documented in [Section 5.15](#))

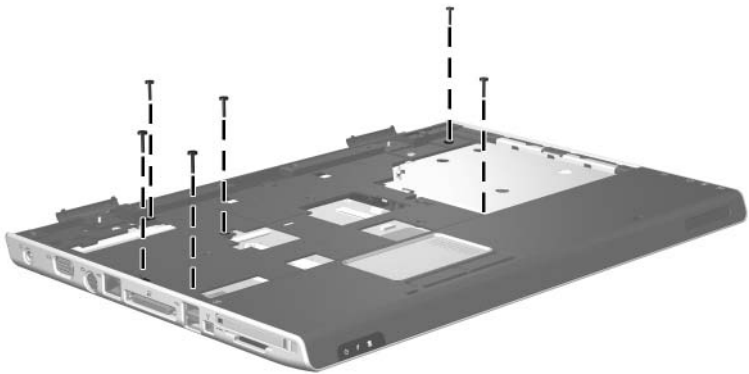

Phillips PM2.5×13.0 Screw Locations

Table C-6
Phillips PM2.5×9.0 Screw

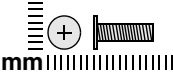
	Color	Qty.	Length	Thread	Head Width
	Black	6	9.0 mm	2.5 mm	4.5 mm

Where used:

5 screws that secure the display assembly to the computer (documented in [Section 5.14](#))

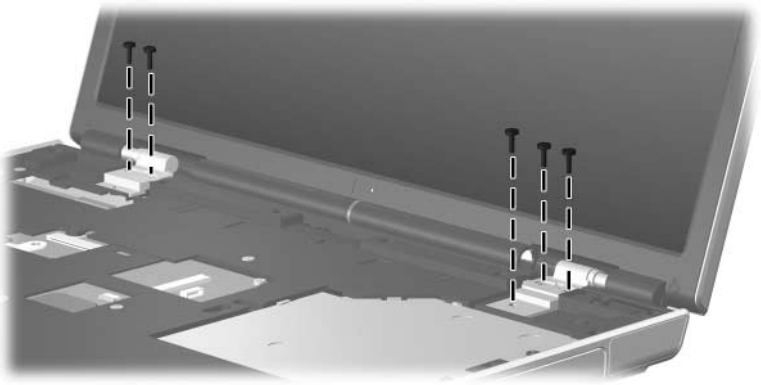

Phillips PM2.5×9.0 Screw Locations

Table C-6
Phillips PM2.5×9.0 Screw (Continued)

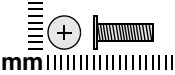
 mm	Color	Qty.	Length	Thread	Head Width
	Black	6	9.0 mm	2.5 mm	4.5 mm

Where used:

One screw that secures the system board to the computer (documented in [Section 5.16](#))

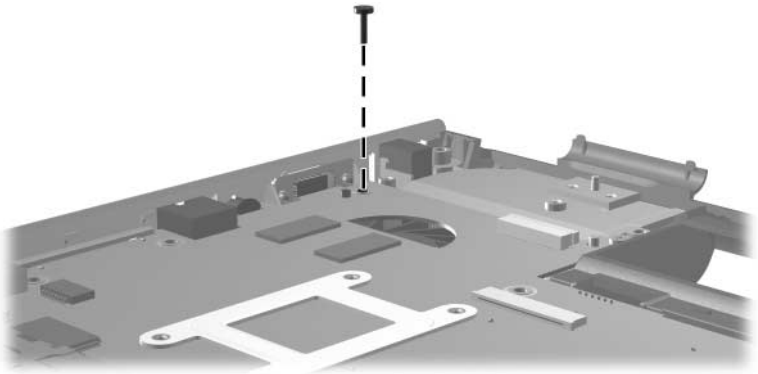

Phillips PM2.5×9.0 Screw Location

Table C-7
Phillips PM2.5×7.0 Screw

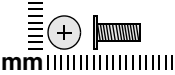
	Color	Qty.	Length	Thread	Head Width
mm	Black	10	7.0 mm	2.5 mm	4.5 mm

Where used:

6 screws that secure the display bezel to the display assembly (documented in [Section 5.14](#))

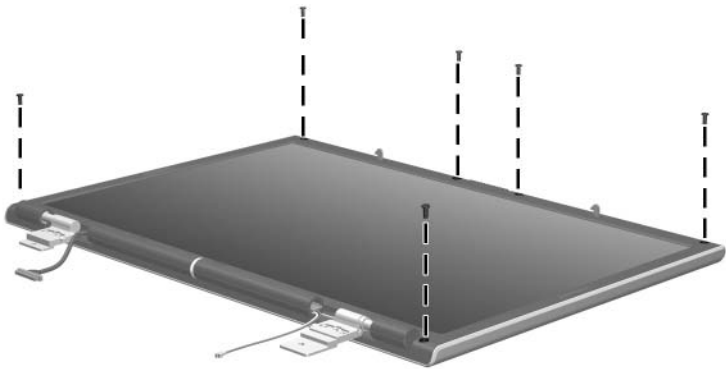

Phillips PM2.5×7.0 Screw Locations

Table C-7
Phillips PM2.5x7.0 Screw (Continued)

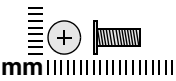
	Color	Qty.	Length	Thread	Head Width
	Black	10	7.0 mm	2.5 mm	4.5 mm

Where used:

2 screws that secure the display panel to the display enclosure (documented in [Section 5.14](#))

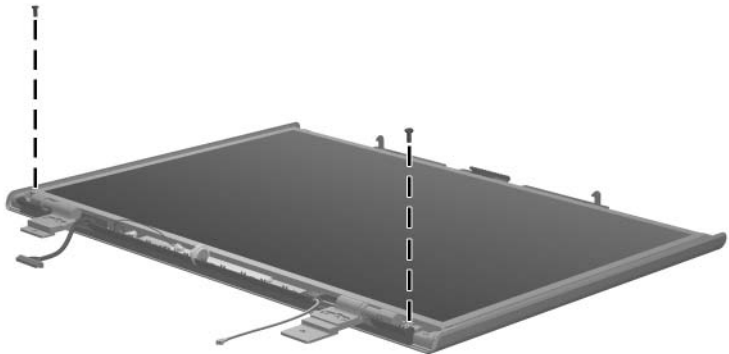

Phillips PM2.5x7.0 Screw Locations

Table C-7
Phillips PM2.5×7.0 Screw (Continued)

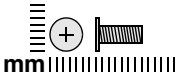
	Color	Qty.	Length	Thread	Head Width
	Black	10	7.0 mm	2.5 mm	4.5 mm

Where used:

2 screws that secure the fan assembly to the system board (documented in [Section 5.23](#))

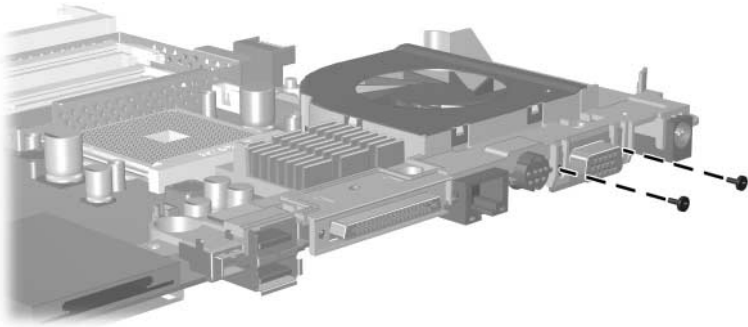

Phillips PM2.5×7.0 Screw Locations

Table C-8
Phillips PM2.0×4.0 Screw

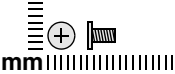
 mm	Color	Qty.	Length	Thread	Head Width
	Black	13	4.0 mm	2.0 mm	4.0 mm

Where used:

8 screws that secure the display hinges to the display panel (documented in [Section 5.14](#))



Phillips PM2.0×4.0 Screw Locations

Table C-8
Phillips PM2.0x4.0 Screw (Continued)

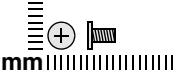
	Color	Qty.	Length	Thread	Head Width
	Black	13	4.0 mm	2.0 mm	4.0 mm

Where used:

One screw that secures the display inverter to the display enclosure (documented in [Section 5.14](#))

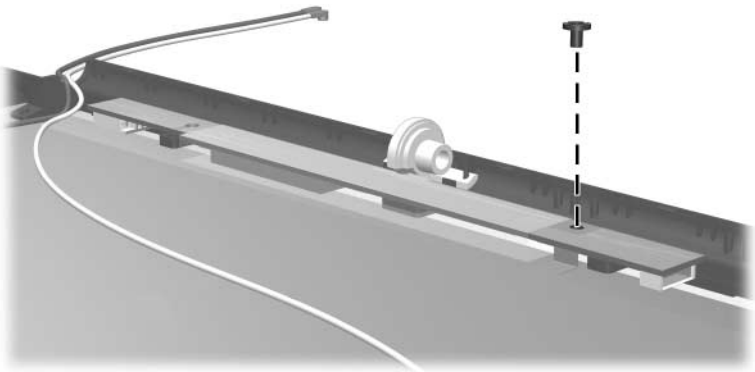

Phillips PM2.0x4.0 Screw Location

Table C-8
Phillips PM2.0×4.0 Screw (Continued)

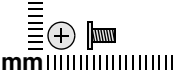
	Color	Qty.	Length	Thread	Head Width
	Black	13	4.0 mm	2.0 mm	4.0 mm

Where used:

2 screws that secure the Bluetooth module to the computer (documented in [Section 5.17](#))

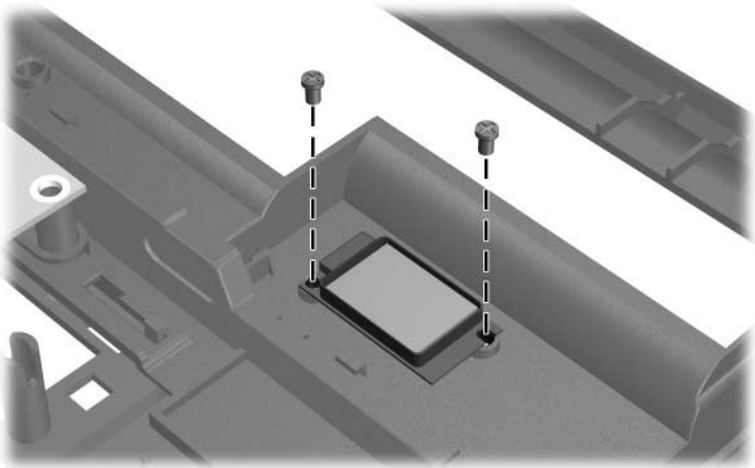

Phillips PM2.0×4.0 Screw Locations

Table C-8
Phillips PM2.0x4.0 Screw (Continued)

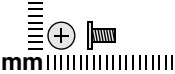
 mm	Color	Qty.	Length	Thread	Head Width
	Black	13	4.0 mm	2.0 mm	4.0 mm

Where used:

2 screws that secure the PC Card assembly to the system board (documented in [Section 5.24](#))

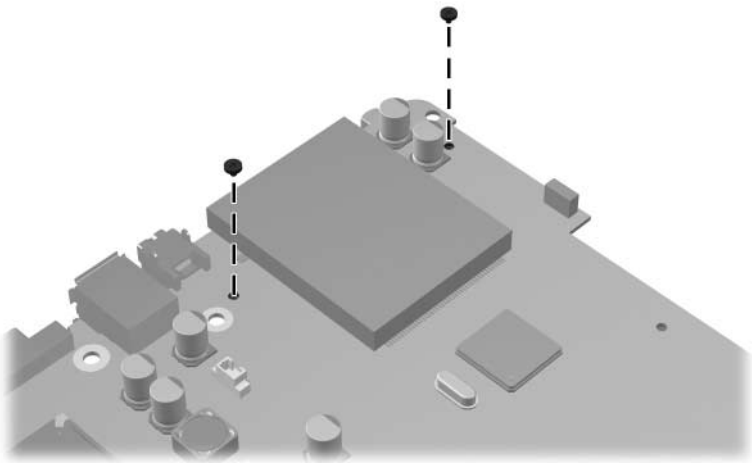

Phillips PM2.0x4.0 Screw Locations

Table C-9
Slotted M1.5×9.0 Screw

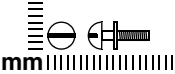
	Color	Qty.	Length	Thread	Head Width
	Silver	2	9.0 mm	1.5 mm	4.0 mm

Where used:

2 screws that secure the fan assembly to the system board (documented in [Section 5.23](#))

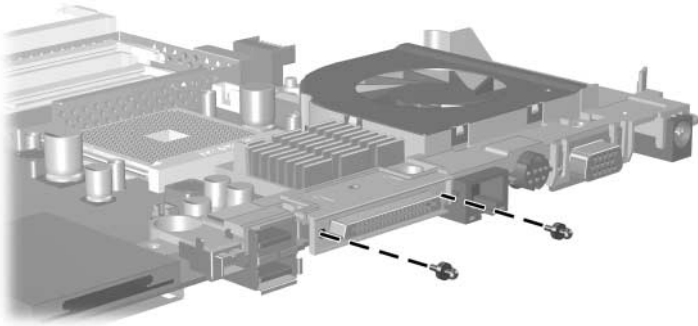

Slotted M1.5×9.0 Screw Locations

Display Component Recycling



WARNING: The backlight contains mercury. Caution should be exercised when removing and handling the backlight to avoid damaging this component and causing exposure to the mercury.



CAUTION: The procedures in this appendix can result in damage to display components. The only components intended for recycling purposes are the liquid crystal display (LCD) panel and the backlight. Careful handling should be exercised when removing these components.



Materials Disposal

This HP product contains mercury in the display assembly backlight and may require special handling at end-of-life.

Disposal of mercury may be regulated because of environmental considerations. For disposal or recycling information, contact your local authorities or visit the Electronic Industries Alliance (EIA) at <http://www.eiae.org>.

This appendix provides disassembly instructions for the display assembly. The display assembly must be disassembled to gain access to the backlight ❶ and the LCD panel ❷.



Disassembly procedures differ from one display assembly to another. The procedures provided in this appendix are general disassembly instructions. Specific details, such as screw sizes, quantities, and locations, and component shapes and sizes, can vary from one computer model to another.

Refer to [Section 5.14, “Display Assembly,”](#) for display assembly disassembly steps.

Perform the following steps to disassemble the display assembly:

1. Remove all screw covers **1** and screws **2** that secure the display bezel to the display assembly.

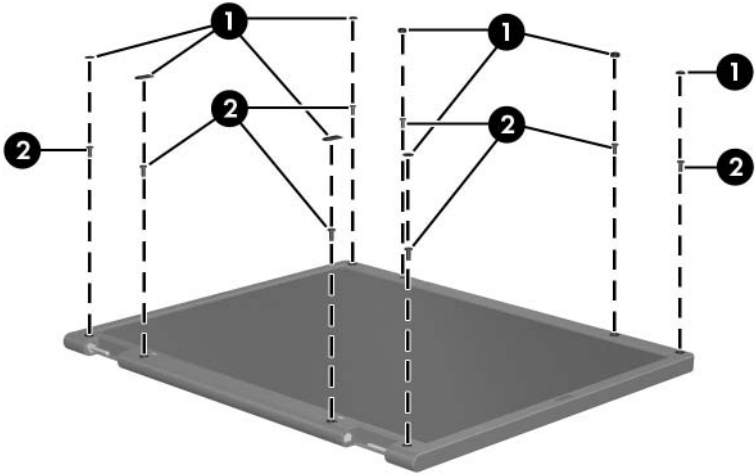

Removing the Display Bezel Screw Covers and Screws

-
2. Lift up and out on the left and right inside edges ❶ and the top and bottom inside edges ❷ of the display bezel until the bezel disengages from the display assembly.
3. Remove the display bezel ❸.

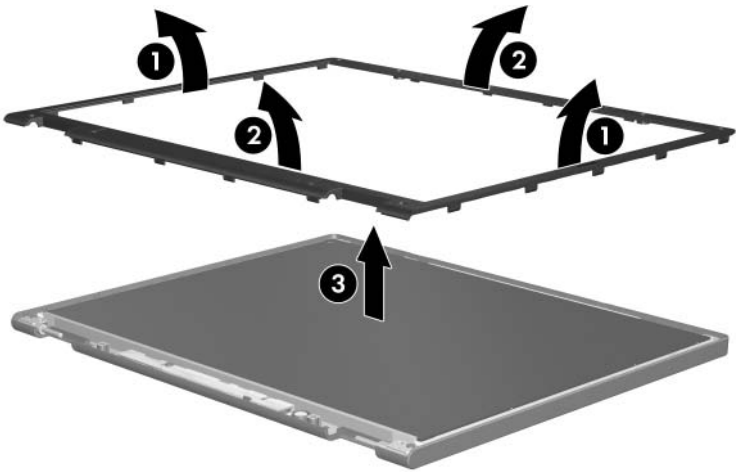

Removing the Display Bezel

4. Disconnect all LCD panel cables ❶ from the display inverter and remove the inverter ❷.

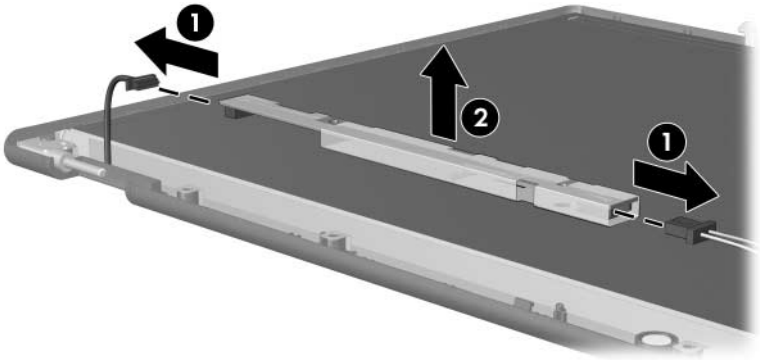

Removing the Display Inverter

5. Remove all screws **1** that secure the LCD panel to the display enclosure.
6. Remove the LCD panel **2** from the display enclosure.

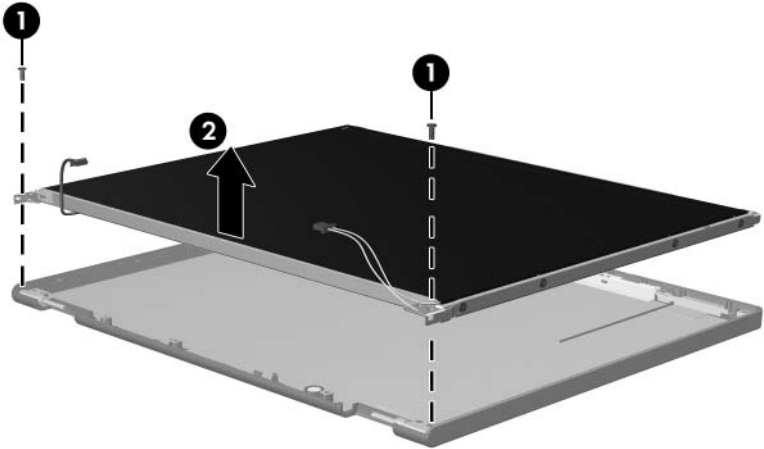

Removing the LCD Panel

7. Turn the LCD panel upside down.
8. Remove all screws that secure the LCD panel frame to the LCD panel.

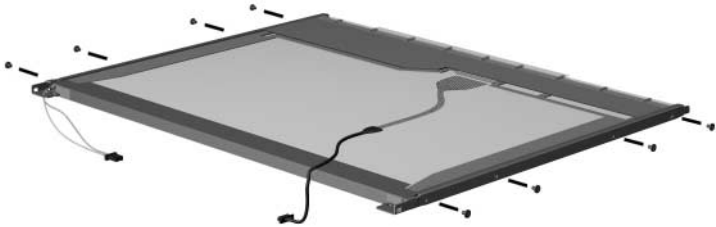

Removing the LCD Panel Frame Screws

9. Use a sharp-edged tool to cut the tape **1** that secures the side of the LCD panel to the LCD panel frame.
10. Remove the LCD panel frame **2** from the display panel.

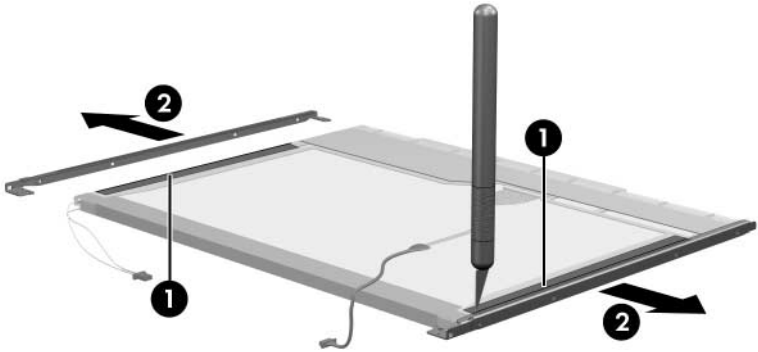

Removing the LCD Panel Frame

11. Remove the screws ❶ that secure the backlight cover to the LCD panel.
12. Lift the top edge of the backlight cover ❷ and swing it forward.
13. Remove the backlight cover.

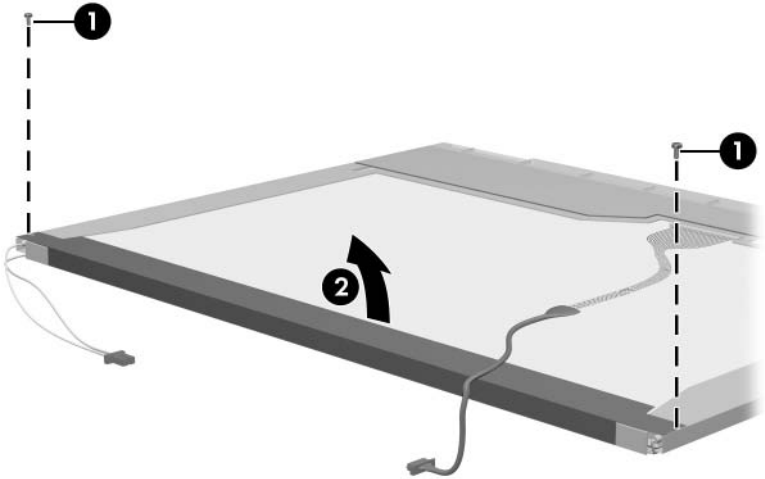

Removing the Backlight Cover

14. Turn the LCD panel right-side up.
15. Remove the backlight cables **1** from the clip **2** in the LCD panel.

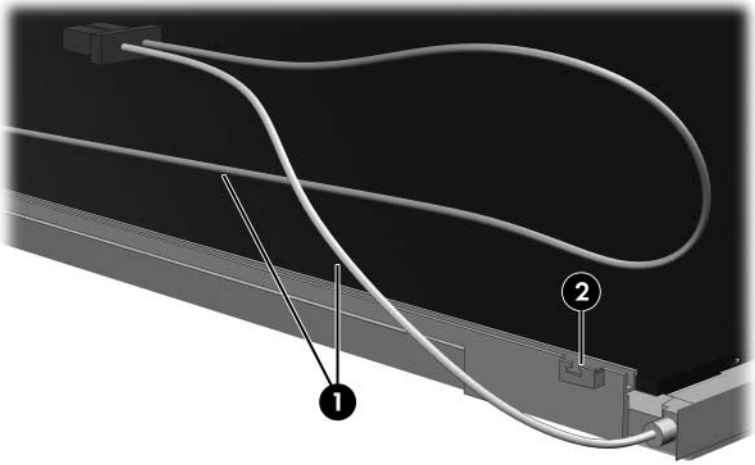

Releasing the Backlight Cables

16. Turn the LCD panel upside down.
17. Remove the backlight frame from the LCD panel.

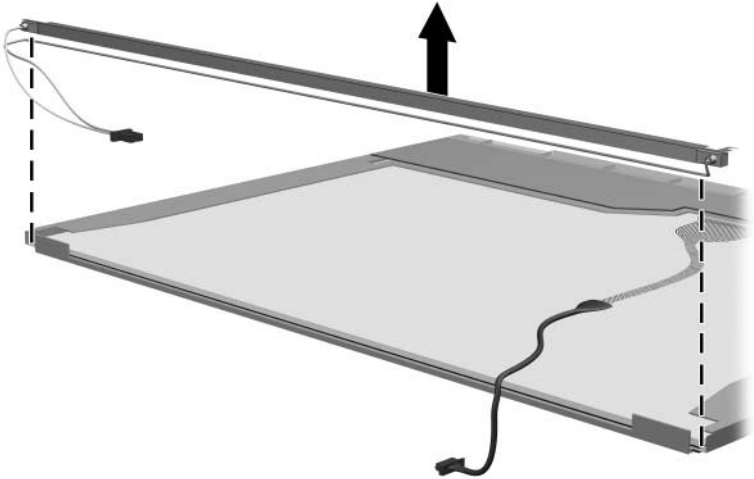

Removing the Backlight Frame



WARNING: The backlight contains mercury. Caution should be exercised when removing and handling the backlight to avoid damaging this component and causing exposure to the mercury.

18. Slide the backlight out of the backlight frame.

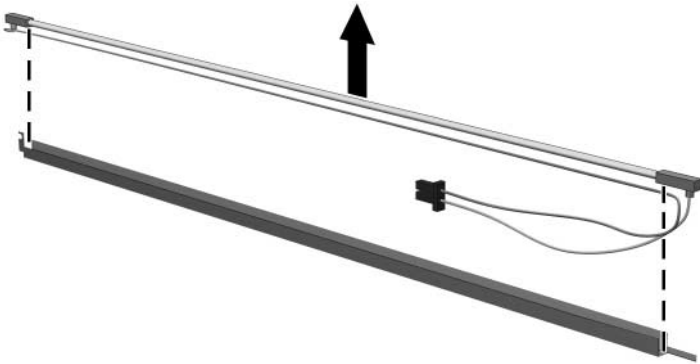

Removing the Backlight

19. Disconnect the display cable **1** from the LCD panel.
20. Remove the screws **2** that secure the LCD panel to the LCD rear panel.
21. Release the LCD panel **3** from the LCD rear panel.
22. Release the tape **4** that secures the LCD panel to the LCD rear panel.

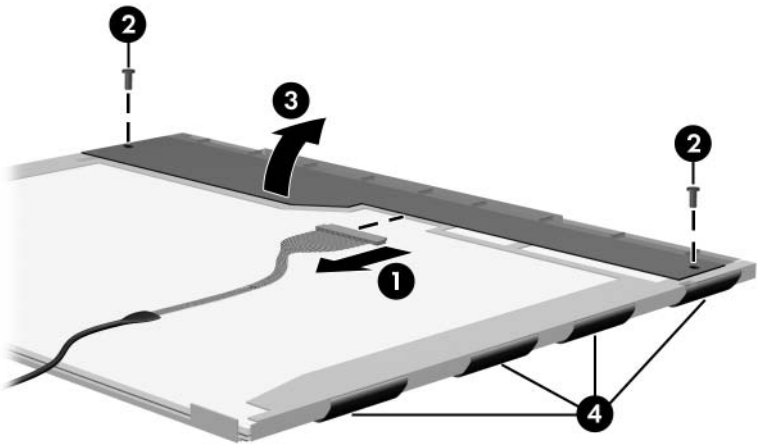

Releasing the LCD Panel

23. Remove the LCD panel.

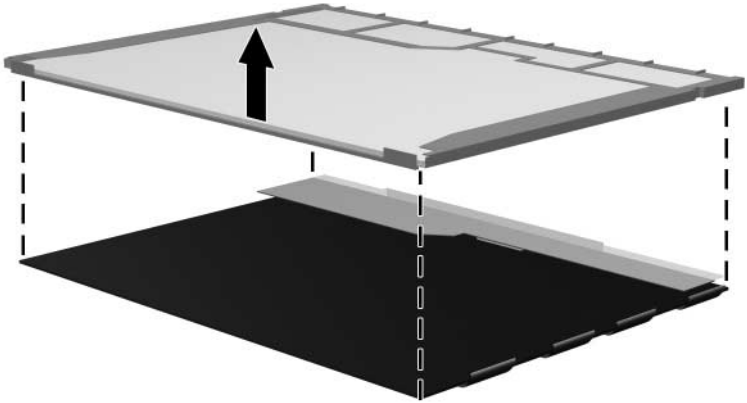

Removing the LCD Panel

24. Recycle the backlight and LCD panel.

Index

1394 port 1–11

A

all-in-one media cable, spare
part number 3–16, 3–17

arrow keys 1–15

audio troubleshooting 2–23

audio Y-cable 2, spare part
number 3–16, 3–17

audio-in jack

location 1–9

pin assignments A–2

audio-out jack

location 1–9

pin assignments A–1

B

base enclosure, spare part
number 3–7, 3–19

battery bay 1–13, 1–22

battery light 1–7

battery pack

removal 5–6

spare part number 3–9,
3–18, 5–5

specifications 6–7

battery release latch 1–22

Bluetooth module

removal 5–57

spare part number 3–7,
3–17, 5–57

Bluetooth module cable

illustrated 3–13

removal 5–59

bottom components 1–22

Bracket Kit

contents 3–5, 3–19

spare part number 3–5,
3–19

C

Cable Kit

components 3–13

spare part number 3–13,
3–19

cables, service considerations
4–2

caps lock key 1–15

components

bottom 1–22

front 1–6

keyboard 1–14

left-side 1–10, 1–12

- right-side 1–8
- top 1–16, 1–18, 1–21
- computer feet
 - illustrated 3–12
 - locations 5–11
- Computer Setup
 - Advanced Menu 2–6
 - File Menu 2–3
 - overview 2–1
 - Security Menu 2–4
 - Tools Menu 2–5
- Computer Setup defaults 2–2
- computer specifications 6–1
- connector pin assignments
 - audio-in A–2
 - audio-out A–1
 - external monitor A–3
 - RJ-11 A–5
 - RJ-45 A–4
 - S-Video-out A–6
 - Universal Serial Bus (USB)
 - A–2
- connectors, service considerations 4–2

D

- design overview 1–24
- Digital Media Slot 1–11
- Digital Media Slot light 1–11
- disassembly sequence chart 5–3
- diskette drive
 - OS loading problems 2–21
 - precautions 4–3
- display assembly
 - removal 5–32
 - spare part numbers 3–3, 3–18, 5–32
 - specifications 6–3, 6–4
- Display Hinge Kit
 - components 3–11, 3–20, 5–40
 - spare part number 3–11, 3–20, 5–40
- display hinge support bracket
 - illustrated 3–5
 - removal 5–52
- display inverter board
 - removal 5–41
 - spare part number 3–11, 3–19, 5–41
- Display Label Kit, spare part number 3–11, 3–20
- Display Panel Kit, spare part number 3–11, 3–20, 5–39
- Display Plastics Kit
 - components 3–11, 3–20, 5–35
 - spare part number 3–11, 3–20, 5–35, 5–42
- display release latch 1–7
- Display Screw Kit, spare part number 3–11, 3–20, 5–35
- display switch 1–16
- docking device,
 - troubleshooting 2–16
- drives, preventing damage 4–3
- DVD/CD-RW Combo Drive
 - OS loading problems 2–22
 - precautions 4–3

- removal 5–20
 - spare part number 3–5, 3–15, 3–18, 5–20
 - specifications 6–8
 - DVD±RW and CD-RW
 - Double Layer Combo Drive
 - OS loading problems 2–22
 - precautions 4–3
 - removal 5–20
 - spare part number 3–5, 3–15, 3–18, 5–20
 - specifications 6–9
 - Double Layer Combo Drive with LightScribe
 - OS loading problems 2–22
 - precautions 4–3
 - removal 5–20
 - spare part number 3–5, 3–15, 3–18, 5–20
 - specifications 6–10
- E**
- electrostatic discharge 4–4, 4–8
 - expansion port 2 1–11
 - expansion port 2 bracket, removal 5–74
 - ExpressCard assembly
 - removal 5–53
 - spare part number 3–7, 3–19
 - ExpressCard slot 1–9
 - ExpressCard slot bezel
 - illustrated 3–12
 - removal 5–51
- external monitor port
 - location 1–10
 - pin assignments A–3
- F**
- f1** to **f12** keys 1–15
 - fan assembly
 - removal 5–72
 - spare part number 3–5, 3–19, 5–72
 - features 1–2
 - feet
 - illustrated 3–12
 - locations 5–11
 - flowcharts, troubleshooting
 - no audio 2–23, 2–24
 - no network/modem connection 2–28
 - no OS loading 2–17
 - no OS loading from diskette drive 2–21
 - no OS loading from hard drive 2–18, 2–19, 2–20
 - no OS loading from optical drive 2–22
 - no power 2–10, 2–12, 2–13
 - no video 2–14, 2–15
 - nonfunctioning device 2–25
 - nonfunctioning docking device 2–16
 - nonfunctioning keyboard 2–26
 - nonfunctioning pointing device 2–27

fn key 1–15

front components 1–6

G

grounding equipment and
methods 4–6

H

hard drive

OS loading problems 2–18

precautions 4–3

removal 5–7

spare part numbers 3–7,
3–15, 3–18, 3–20, 5–7

specifications 6–5

hard drive bay 1–23

hard drive cover

illustrated 3–12

removal 5–8

hard drive light 1–7

headphone jack, pin

assignments A–1

headset, spare part number

3–16, 3–17

heat sink

removal 5–67

spare part number 3–5,
3–19, 5–67

HP remote control, spare part

number 3–16, 3–17

I

I/O address specifications

6–15

interrupt specifications 6–13

K

keyboard

removal 5–30

spare part numbers 3–3,
3–18, 5–30

troubleshooting 2–26

keyboard assembly frame

removal 5–24

spare part number 3–3,
3–19, 5–24

keyboard components 1–14

keypad keys 1–15

L

LED board

removal 5–28

spare part number 3–3,
3–19, 5–28

left-side components 1–10,

1–12

M

mass storage devices, spare
part numbers 3–14

media cable, spare part number

3–16, 3–17

memory map specifications

6–18

memory module

removal 5–12

spare part numbers 3–9,
3–17, 3–18, 5–12

memory shield, release 5–14

memory/Mini PCI module
 compartment cover
 illustrated 3-12
 location 1-23
 removal 5-13
microphone jack, pin
 assignments A-2
Mini PCI communications
 module
 removal 5-16
 spare part numbers 3-9,
 3-17, 3-18
modem connector cable
 illustrated 3-13
 removal 5-60
modem jack
 location 1-13
 pin assignments A-5
modem, troubleshooting 2-28

N

network jack
 location 1-10
 pin assignments A-4
network, troubleshooting 2-28
nonfunctioning device,
 troubleshooting 2-16, 2-25

num lock key 1-15

O

optical drive
 location 1-9, 1-22
 OS loading problems 2-22
 precautions 4-3
 removal 5-20

 spare part numbers 3-5,
 3-15, 5-20
 specifications 6-8
optical drive connector board
 removal 5-56
 spare part number 3-5,
 3-19

P

packing precautions 4-5
PC Card assembly
 removal 5-76
 spare part number 3-7,
 3-20, 5-76
PC Card eject button 1-11
PC Card slot 1-11
PC Card slot bezel, illustrated
 3-12
plastic parts 4-2
Plastics Kit
 components 3-12
 spare part number 3-7,
 3-12, 3-19
pointing device,
 troubleshooting 2-27
power button 1-17
power connector 1-10
power connector cable
 illustrated 3-13
 removal 5-75
power cord
 set requirements B-2
 spare part numbers 3-16,
 3-19
power light 1-7, 1-17

- power management features
1–5
- power supply, spare part
number 3–16, 3–19
- power, troubleshooting 2–10
- precautions
 - DVD/CD-RW Combo
Drive 4–3
 - DVD±RW and CD-RW
Double Layer Combo
Drive 4–3
 - DVD±RW and CD-RW
Double Layer Combo
Drive with LightScribe
4–3
 - hard drive 4–3
 - optical drive 4–3
- processor
 - removal 5–70
 - spare part numbers 3–7,
3–17, 5–70

Q

- Quick Launch calculator
button 1–20

R

- remote control, spare part
number 3–16, 3–17
- removal/replacement
 - preliminaries 4–1
 - procedures 5–1
- right-side components 1–8
- RJ-11 jack
 - location 1–13
 - pin assignments A–5
- RJ-45 jack
 - location 1–10
 - pin assignments A–4
- RTC battery
 - removal 5–18
 - spare part number 3–7,
3–19, 5–18

S

- Screw Kit
 - contents C–1
 - spare part numbers 3–11,
3–16, 3–19, 3–20, 5–35,
C–1
 - screw listing C–1
- security cable slot 1–13
- serial number 3–1, 5–2
- service considerations 4–2
- speakers
 - location 1–7
 - removal 5–64
 - spare part number 3–5,
3–19, 5–64
- specifications
 - battery pack 6–7
 - computer 6–1
 - display assembly 6–3, 6–4
 - DVD/CD-RW Combo
Drive 6–8
 - DVD±RW and CD-RW
Double Layer Combo
Drive 6–9
 - DVD±RW and CD-RW
Double Layer Combo
Drive with LightScribe
6–10

- hard drive 6–5
- I/O addresses 6–15
- interrupts 6–13
- memory map 6–18
- optical drive 6–8
- system DMA 6–12
- static shielding materials 4–8
- S-Video-out jack
 - location 1–10
 - pin assignments A–6
- switch cover
 - removal 5–22
 - spare part number 3–3, 3–19, 5–22
- system board
 - removal 5–50
 - spare part number 3–5, 3–17, 5–50
- system DMA 6–12
- system memory map 6–18

T

- tools required 4–1
- top components 1–16, 1–18, 1–21
- top cover
 - removal 5–43
 - spare part number 3–5, 3–19, 5–43
- TouchPad cable
 - disconnection 5–44
 - illustrated 3–13
- transporting precautions 4–5
- troubleshooting
 - audio 2–23
 - Computer Setup 2–2

- docking device 2–16
- flowcharts 2–7
- keyboard 2–26
- modem 2–28
- network 2–28
- nonfunctioning device
 - 2–16, 2–25
- OS loading 2–17
- overview 2–1
- pointing device 2–27
- power 2–10
- video 2–14

U

- Universal Serial Bus (USB)
 - port
 - location 1–9, 1–11
 - pin assignments A–2

- USB board
 - removal 5–62
 - spare part number 3–5, 3–19, 5–62

- USB board cable
 - illustrated 3–13
 - removal 5–63

- USB digital drive, spare part number 3–15, 3–16, 3–17

- USB travel mouse, spare part number 3–16, 3–17

V

- vent, locations 1–13, 1–23
- video troubleshooting 2–14
- volume buttons 1–17

W

Windows applications key
1–15

Windows logo key 1–15

wireless antenna
removal 5–42
spare part number 3–11,
3–20, 5–42

wireless button 1–17

wireless light 1–13, 1–16

workstation precautions 4–6